



The Leader in Event Critical Timing Electronics

Wireless Auto Timer

*Models 4508BW/4808BW/4408W
6508BW/6808BW/6408W*

Rev B



RaceAmerica Corporation
P.O. Box 3469
Santa Clara, CA 95055-3469
(408) 988-6188
<http://www.raceamerica.com>
info@raceamerica.com

Copyright 2008 RaceAmerica Corporation

Table of Contents

LIMITED WARRANTY3

PRODUCT OVERVIEW4

PACKAGE COMPONENTS4

AVAILABLE OPTIONS.....4

POWER REQUIREMENTS4

PRODUCT SPECIFICATIONS5

TIMER SET-UP6

CONFIGURE MODE.....6

DIAGNOSTIC MODE7

CHARGE BATTERY8

POWER-ON SELF-TEST.....8

TIMER OPERATION8

MAINTENANCE.....9

SPARE PARTS.....9

SUPPORT AGREEMENTS.....9

RACEAMERICATM

T i m i n g S y s t e m s

LIMITED WARRANTY

To the original purchaser of this RaceAmerica product, RaceAmerica warrants it to be in good working order for a period of ninety (90) days from the date of purchase from RaceAmerica or an authorized RaceAmerica distributor. Should this product malfunction during the warranty period, RaceAmerica will, at its option, repair or replace it at no charge, provided the product has not been subjected to misuse, abuse, or alterations, modifications, and/or repairs not authorized by RaceAmerica.

Any product requiring Limited Warranty service during the warranty period should be returned to RaceAmerica with proof of purchase. If return of merchandise is by mail, the customer agrees to insure the product, prepay shipping charges, and ship the product to RaceAmerica, Inc., 280 Martin Avenue Unit 1, Santa Clara, CA 95050.

ALL EXPRESSED AND IMPLIED WARRANTIES FOR THIS PRODUCT ARE LIMITED IN DURATION TO THE ABOVE NINETY DAY PERIOD.

UNDER NO CIRCUMSTANCES WILL RACEAMERICA BE LIABLE TO THE USER FOR DAMAGES, INCLUDING ANY LOST PROFITS, LOST SAVINGS, OR OTHER INCIDENTAL OR CONSEQUENTIAL DAMAGES ARISING OUT OF THE USE OF, OR INABILITY TO USE, SUCH PRODUCT.

THIS WARRANTY GIVES YOU SPECIFIC LEGAL RIGHTS, AND YOU MAY ALSO HAVE OTHER RIGHTS WHICH MAY VARY FROM STATE TO STATE.

PRODUCT OVERVIEW

RaceAmerica's Wireless Auto Timer is available in several four and six digit models with three digit heights (5"/13cm, 8"/20cm, and 24"/61cm). Integrated internal wireless and rechargeable batteries are contained within the Display timer unit and remote T-Link sensors. All models operate wirelessly. The Wireless Auto Timers operate in conjunction with RaceAmerica's T-Link Wireless Track Sensors and provide accuracy to 0.001 seconds.

The Wireless Auto Timers contain the capability to time up to two racers on course at a time in a serial starting format and first-in-first-out timing method. Timing parameters can be configured by the operator and saved onboard in flash memory. The timing system operates under the premise of a metered minimum time between starts and a maximum time after which the run timing is aborted in the event a racer is unable to complete a run. RaceAmerica's T-Link Wireless Track Sensor technology enables accurate wireless timing of race events where the start and finish lines can be separated by several thousand feet with line of sight.

Timing parameters are selected for Display Hold Time, Average Time and Delta Time. Display Hold Time determines the number of seconds the last completed run will display before advancing to the live counting of the next racer already on course. Average Time plus Delta determines the maximum run time in seconds. When the timer reaches the maximum, timing for that racer is aborted. This function is required to enable the Wireless Auto Timer to be completely standalone. Average Time minus Delta Time determines the minimum time between starts by locking out the start sensor from detecting a new start. During the start sensor lockout period, an optional Metering Light can be connected to the start T-Link unit to indicate when the next racer may start. The Metering Light illuminates when a racer starts and remains illuminated until the start sensor is no longer locked out.

The Wireless Auto Timer and the two T-Link wireless units contain rechargeable batteries. Batteries can be recharged in a few hours using the battery charger included with the timing system.

NOTE: THIS PRODUCT USES ULTRA-BRIGHT LED TECHNOLOGY. DUE TO THE BRIGHTNESS LEVEL OF THIS DISPLAY, CARE SHOULD BE TAKEN, AS WITH ANY BRIGHT LIGHTING SOURCE, TO AVOID PROLONGED VIEWING AT CLOSE RANGE AND SHORT DISTANCES. AS WITH ANY BRIGHT LIGHTING SOURCE, VISION MAY BE AFFECTED SHORT TERM SIMILAR TO A CAMERA FLASH.

PACKAGE COMPONENTS

Each Display Timer package includes:

- 1 - Display Timer with antenna/internal battery
- 1 - Battery charger
- 2 - 5040B Beam Emitters
- 2 - 5805C Wireless Track Sensor
('A' label Start, 'B' label Finish)
- 1 - Owners Manual

AVAILABLE OPTIONS

- High gain antenna - increase range to miles
- Long range Emitters -
 - 5050 -75ft, 5060 -150ft
 - 3221M Metering Light with 10ft cable
 - 6070B Blow Molded sensor case (2 ea)
 - 6075A Soft side case - 5" display
 - 6077A Soft side case - 8" display
 - 7540 Foam Stands (for 5040/5050 emitters)
 - 7606B Suspension arm stand for (6" & 8")

POWER REQUIREMENTS

The Wireless Auto Timer, sensors and emitters operate on internal sealed batteries. During recharge of the battery, the operational functions are disabled to avoid damage. Wireless Auto Timers with twenty-four inch digits (4408W/6408W) require a 110/230VAC power adapter or a 25VDC power source.

PRODUCT SPECIFICATIONS

Timer Model	4508BW	4808BW	4408W	6508BW	6808BW	6408W
Digit Size	5" /13cm	8"/20cm	24"/61cm	5"/13cm	8"/20cm	24"/61cm
Display Type:			7-Segment			
Number of digits:	Four	Four	Four	Six	Six	Six
Enclosure Dims (in)	20.3x13.3x3"	32.3x15.3x3"	90x29x4"	29.5x13.3x3"	46.75x15.3x3"	135x29x4"
Mounting - Eyelets	16.63" Center	20.3" Center	Structure	23" Center	30" Center	Structure
Enclosure Finish	Powder Coated Steel	Powder Coated Aluminum	Powder Coated Steel	Powder Coated Steel	Powder Coated Steel	Powder Coated Steel
View Filter			Red transparent acrylic			
View Range (ft)	200	320	1000	200	320	1000
Timing:						
(Sec.Fractions)	05.00 to 90.00				005.000 to 090.000	
Operating Range			20°F to 120°F			
Battery life (Hrs)						
Display	16	12	N/A	14	10	N/A
T-Link			20			

TIMING ELECTRONICS

- Beam Emitter - 5040

Beam Type:	Coded Infra-red
Enclosure Dims	5.3 X 2.5 X 2.3"
Enclosure Finish	Powder Coated Aluminum
Beam Range:	50 ft (options)
Battery Life:	60 hrs

- T-Link Wireless Sensor - 5805

Wireless RF range:	1000ft (options)
Enclosure Dims	7.4 X 7 X 3"
Enclosure Finish	Powder Coated Steel
Battery Life	20 hours

TIMER SET-UP

The Wireless Auto Timer is set-up as shown in Figure 1 below. The timer ships from the factory ready to operate after set-up, power-on and beam alignment. The timer includes separate Configure and Diagnostic modes; Configure is used to set the timing parameters - Display Hold time, Average Run time and Run Delta time; Diagnostic

mode is used to check RF signal strength, Sensor Alignments and Battery levels in the Wireless T-Link units.

To enter Configure or Diagnostic modes, press and hold the **RESET** button on the rear of the Display while powering up the display. **[CFG]** is displayed for a few seconds, then **[diAG]** is displayed for a few seconds. The display toggles between these two. To verify or reconfigure the timing parameters of the timer, release the **RESET** button when **[CFG]** is displayed. To enter Diagnostic Mode, release the **RESET** button when **[diAG]** is displayed.

CONFIGURE MODE

The main three timing parameters are Display Hold Time, Average Elapsed Time, and Delta Time. The Display Hold Time is the time in seconds the last racer's time will be displayed after a finish and displayed as **[H xx]** with xx flashing. Choices are 05, 07 10, 15, and 20 seconds. To advance through the choices, press and release the **RESET** button.

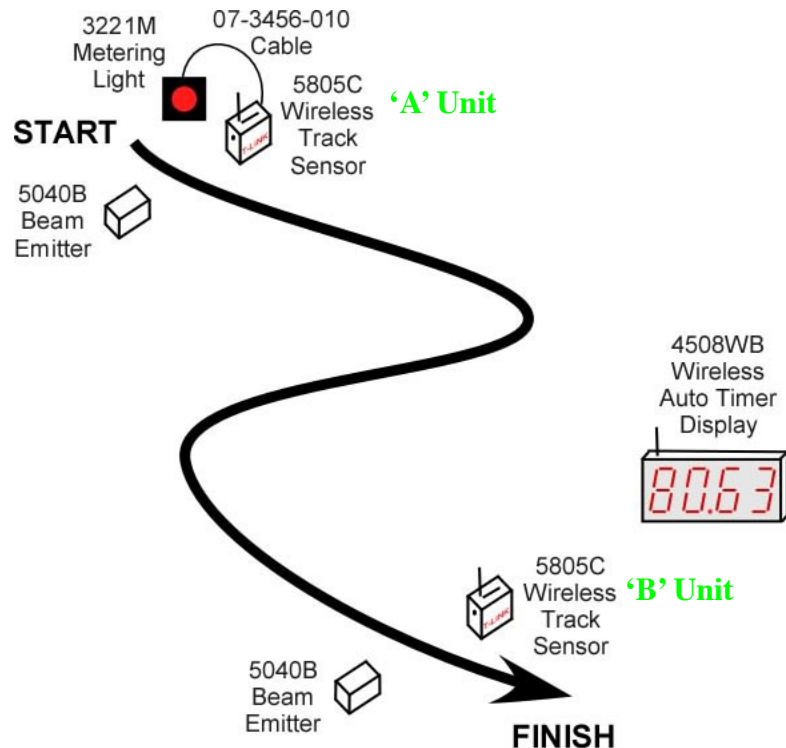

Figure 1 - Typical setup of sensors, emitters and the display

When the desired time is displayed, press and hold the **RESET** button until the display changes to [A xx] where xx is flashing to set Average Time. The Average Time and the Delta Time interact to provide the minimum time between consecutive starts and the maximum elapsed time before the timer aborts the run. Average Time minus Delta Time equals the minimum time between starts. Average Time plus Delta Time is the maximum run time. Choices for Average Time are 20, 30, 40, 50, and 60 seconds. To advance through the choices, press and release the **RESET** button.

When the desired time is displayed, press and hold the **RESET** button until the display changes to [d xx] where xx is flashing to set the delta time. Choices for Delta Time are 10, 15, 20, 25, and 30 seconds. To advance through the choices, press and release the **RESET** button.

When the desired time is displayed, press and hold the **RESET** button until the display clears or [Err] is displayed. If [Err] is displayed, the selected values for the timing parameters create an error condition. If the Hold Time is greater than the Average + Delta Time or the Delta Time is greater than Average Time, an error condition occurs and the display starts over prompting for the Display Hold Time. When the display clears, the selections are saved to memory. Restart the display to begin timing after the power-up sequence completes.

DIAGNOSTIC MODE

Diagnostic Mode consists of four tests to assist troubleshooting setup and operation of the Standalone Display Timer timing system. Tests are as follows:

- Test the one way wireless connectivity between the display and the T-Link wireless track electronics
- Monitor and display the wireless integrity level to determine signal strength and wireless interference level in the area
- Monitor and display the battery level of the

T-Link wireless track electronic sensor units

- Monitor and display the alignment status of the start and finish beams

Diagnostic mode begins with [Send] displayed, the receive status LED off, and the transmit status LED on blinking off momentarily. The T-Link Wireless Sensors will indicate they are receiving the signal by blinking the center LED and the right LED is constantly on.

Press and release the **RESET** button to advance to monitor the wireless RF signal integrity with [-rf-] displayed. The left dash is the start line and the right dash is the finish line. The dashes on the display will begin to count up as signals are received from the T-Link units on the track. 0 displayed represents 0%, 1 represents 10%, 2 represents 20% etc. until a dash appears representing 100%. This is an indication of the consistency of the RF signal integrity. If this number jumps around, there is a high level of interference in the area. If the number remains high, the RF signal strength is very good. If the number remains low, the RF signal is somewhat weak. The position of the T-Links and display can be moved to optimize the RF Integrity level.

Press and release the **RESET** button to advance to monitor the Battery Level of the T-Links on the track indicated by [-bL-] displayed. The left dash is the start line and the right dash is the finish line. The dashes will be replaced by the percentage of battery power remaining. 0 for 0%, 1 for 10%, 2 for 20%, etc and a dash for 100%.

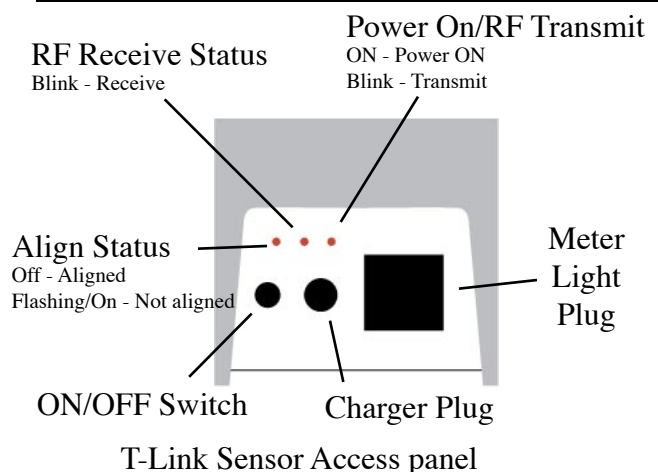

Press and release the **RESET** button to advance to monitor the sensor alignment at the start and finish lines indicated by [-SF-] displayed. The left dash is the start line and the right dash is the finish line. The dashes will be replaced by a number. The sensors are checked continuously and the display is updated 4 times a second. If the sensor is aligned, the number will not change. If the sensor is intermittently out of alignment or on the edge of alignment, the corresponding number will count intermittently. If the sensor is out of alignment, the corresponding number will count 4 times a second.

Press and release the **RESET** button to loop back to the [Send] transmit test mode. To exit Diagnostic Mode, power off the timer.

CHARGE BATTERY

Charge the batteries with the charger unit(s). All functional electronics are disabled during battery recharge to avoid damage. Typically battery charging will take 12 hours; the charger indicator LED will turn from red to green when charging is complete.

POWER-ON SELF-TEST

When the timer power switch is turned on, the display timer begins an internal self-test and an external visual check of the display elements.

The self-test begins by stepping through each segment of all digits, one segment at a time including the colon or decimal point which exist to the right of each digit except the rightmost digit. The self-test continues by sequentially illuminating each segment until all segments, colons, and decimal points are on. Then the revision level of the code (eg [-A.0-]) running in the microprocessor is displayed, then blanks out.

The display is ready to begin receiving sensor inputs. Power-on the sensors and emitters; the right red LED on the sensor access panel indicates power is on.

If the optional Metering Light is to be used,

connect it to the connector on the Start sensor (5805C labeled 'A'). The light will turn on to hold up starting and turn off when it is OK to start; this is determined by the average time less the delta time.

TIMER OPERATION

In Operational mode, the timer waits for a start to occur. When it does, the display will begin to show the 'unofficial time' until there is a finish when the display will stop counting and freeze the 'official time' for the configured Hold time; then blank out. A second racer can start on course after the sensor is reactivated (Average time less Delta time). The 'unofficial time' of the second racer will display after the 'Hold time' expires on the racer in front of them. This procedure can be endlessly repeated. If a racer starts too early, they will get no time; if a racer goes off course or does not finish within the maximum time (average time plus delta time), the 'unofficial time' display will blank and they will get no time. The system automatically corrects for these conditions as long as a 'no time' racer finishes on someone else's time.

During timer operation the following conditions apply:

Average Time + Delta Time = Maximum time before the display will auto blank.

Average Time - Delta Time = Minimum time between starts.

The display will show the error message [Err] if the Delta Time is => the Average Time.

Pressing the RESET switch will clear the displayed time in the timer.

MAINTENANCE

The Wireless Auto Timer, Beam Emitters, and Track Sensors require minimal maintenance.

Periodically clean off the red acrylic front of the display with a soft wet rag; be careful not to scratch the surface with dust or sand which may be on the front or in the rag.

To insure uninterrupted operation on race day, it is suggested to keep track of battery usage hours so as to have fully charged batteries. Plan to recharge the display each day and the Sensor units when the battery level falls below 60% or each weekend. To maintain the highest level of timing accuracy and minimize false trips, annual preventive maintenance and calibration should be performed on all system track sensors and beam emitter units.

SPARE PARTS

Further to minimize race program interruptions, RaceAmerica recommends some spare parts. A spare emitter/sensor pair should be available in the event of an unfortunate accident during a program. Contact RaceAmerica for availability and pricing of spares items.

SUPPORT AGREEMENTS

Support agreements are available from RaceAmerica providing Telephone Assistance on technical issues and operational questions, repair and/or replacement of hardware failures, Software and Firmware updates and bug reporting, and Annual Preventive Maintenance on all system track sensors and beam emitter units. Contact RaceAmerica for more information and pricing of Support Agreements.