

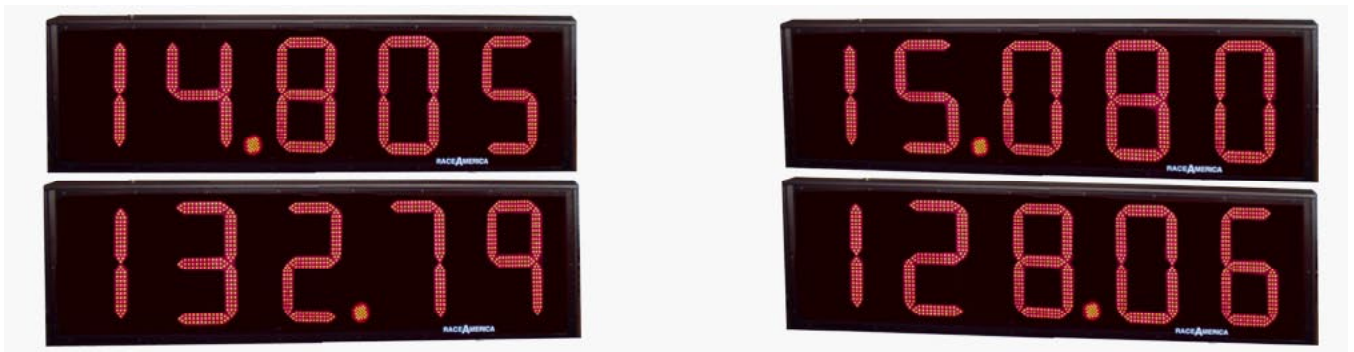

The Leader in Event Critical Timing Electronics

Drag Racing Scoreboards

Interfaced to Port-A-Tree Silver & Gold



Owner Manual's

Models 6629, 6429, 6611 & 6411
Revision D

RaceAmerica Corporation
P.O. Box 3469
Santa Clara, CA 95055-3469
(408) 988-6188
<http://www.raceamerica.com>
info@raceamerica.com

Copyright 2008 RaceAmerica Corporation

Table of Contents

LIMITED WARRANTY	3
PRODUCT OVERVIEW	4
SCOREBOARD SET-UP.....	4
POWER-ON SELF-TEST.....	5
SCOREBOARD OPERATION	6
DIP SWITCH DEFINITIONS.....	6
INDIVIDUAL MODEL SPECIFICATIONS & DETAILS.....	8-13
6629 15in Single Line	8
6429 24in Single Line.....	10
6611 15in Dual Line	12
6411 24in Dual Line	13
SCOREBOARD MAINTENANCE.....	15
SUPPORT AGREEMENTS.....	15

Figures

FIGURE 1 - RS485 NETWORK PC SET-UP	5
FIGURE 2 - SCOREBOARD PC SET-UP	5
FIGURE 3 - 24" UNIT ASSEMBLY	7
FIGURE 4 - 15" DIP SWITCHES.....	7
FIGURE 5 - 24" DIP SWITCHES.....	7
FIGURE 6 - 15" SCOREBOARD MOUNTING	9
FIGURE 7 - 24" SCOREBOARD ASSEMBLY & MOUNTING.....	11
FIGURE 8 - WIRELESS SET-UP DIAGRAM	14

RACEAMERICA

T i m i n g S y s t e m s

LIMITED WARRANTY

To the original purchaser of this RaceAmerica product, RaceAmerica warrants it to be in good working order for a period of ninety (90) days from the date of purchase from RaceAmerica or an authorized RaceAmerica distributor. Should this product malfunction during the warranty period, RaceAmerica will, at its option, repair or replace it at no charge, provided the product has not been subjected to misuse, abuse, or alterations, modifications, and/or repairs not authorized by RaceAmerica.

Any product requiring Limited Warranty service during the warranty period should be returned to RaceAmerica with proof of purchase. If return of merchandise is by mail, the customer agrees to insure the product, prepay shipping charges, and ship the product to RaceAmerica, Inc., 280 Martin Avenue Unit 1, Santa Clara, CA 95050.

ALL EXPRESSED AND IMPLIED WARRANTIES FOR THIS PRODUCT ARE LIMITED IN DURATION TO THE ABOVE NINETY DAY PERIOD.

UNDER NO CIRCUMSTANCES WILL RACEAMERICA BE LIABLE TO THE USER FOR DAMAGES, INCLUDING ANY LOST PROFITS, LOST SAVINGS, OR OTHER INCIDENTAL OR CONSEQUENTIAL DAMAGES ARISING OUT OF THE USE OF, OR INABILITY TO USE, SUCH PRODUCT.

THIS WARRANTY GIVES YOU SPECIFIC LEGAL RIGHTS, AND YOU MAY ALSO HAVE OTHER RIGHTS WHICH MAY VARY FROM STATE TO STATE.

PRODUCT OVERVIEW

RaceAmerica Drag Race Scoreboards are a microprocessor controlled system based upon the 7-segment format display digit using the latest technology Ultra-Bright LEDs. The scoreboard uses a serial link (RS422/RS485) to receive data to be displayed. Each scoreboard contains its own CPU chip to analyze the data string received and correctly display the desired race results (e.g. left/right lane, top/bottom position).

Scoreboards can display race results and a test pattern from Port-A-Tree Silver & Gold Timing system. ET, Speed and Dial-ins, etc. are controlled by the Porta-A-Tree Professional software.

Data communication to all models is available via internal wireless data link units (requires timer side wireless transmitter).

Multiple scoreboards can be daisy positioned down the track for spectator viewing and controlled from a single wireless transmission.

Scoreboards are available in single or dual line formats in fifteen and twenty-four inch digit heights for viewing up to 1000 ft away. Each product is addressed for its unique properties in this manual.

NOTE: THESE PRODUCTS USE ULTRA-BRIGHT LED TECHNOLOGY. DUE TO THE BRIGHTNESS LEVEL OF THIS DISPLAY, CARE SHOULD BE TAKEN, AS WITH ANY BRIGHT LIGHTING SOURCE, TO AVOID PROLONGED VIEWING AT CLOSE RANGE AND SHORT DISTANCES. AS WITH ANY BRIGHT LIGHTING SOURCE, VISION MAY BE AFFECTED SHORT TERM SIMILAR TO CAMERA FLASHES.

SCOREBOARD SET-UP

STEP 1 - Assemble/mount the scoreboard

Each scoreboard model and race track have unique requirements; see suggestions and instructions with each respective model in this manual. Hanging or hard mounting suggestions are provided for each enclosure.

Twenty-four inch models are assembled using the digit position labels located on the top of each digit (segment is identified by the inverse printing of its number). A full unit consists of segments one thru five assembled from left to right.

Connect the cable to the connector between each two digits as they are assembled. A horizontal and vertical frame structure is required to mount each scoreboard (see figures).

STEP 2 - Configure the scoreboard

The scoreboards ship from the factory with the most likely selections enabled. See DIP switch definitions to change scoreboard positions.

NOTE: IF DIP SWITCH NUMBER 1 (BANK S1) IS SET TO 'OFF' DURING THE POWER UP SELF-TEST, THE DISPLAY WILL CONTINUOUSLY LOOP ON THE SELF-TEST UNTIL SWITCH NUMBER 1 IS SET TO THE 'ON' POSITION.

STEP 3 - Connect the interface

Fifteen and twenty-four inch models must receive RS422/RS485 data via a Wireless 'receive' Link mounted internally and configured to receive RS422/RS485 data.

A timer side wireless link transmitter is all that is required to send data to the scoreboards.

The 04-0042 cable must receive data per the following cable pinouts at the timer end:

Pin #	Wire Color	Function
8	wht/blu	Ground
7	blu	Ground
6	wht/brn	Not connected
5	brn	Not connected
4	wht/grn	RS422/RS485+ (positive)
3	grn	RS422/RS485- (negative)
2	wht/org	Ground
1	org	Ground

The scoreboards are configured in the PC software using the RS485 Network Set-up screen and the Scoreboard set-up screen as shown in Fig 1 and Fig 2. If selections are grayed out, the proper software drivers may not be properly installed in your computer

STEP 4 - Connect the power

Power is supplied to each scoreboard unit through the DC POWER INPUT connector located on the rear of the display. Connecting power to the display will set the display into a power-up self-test mode. Once the self-test has successfully

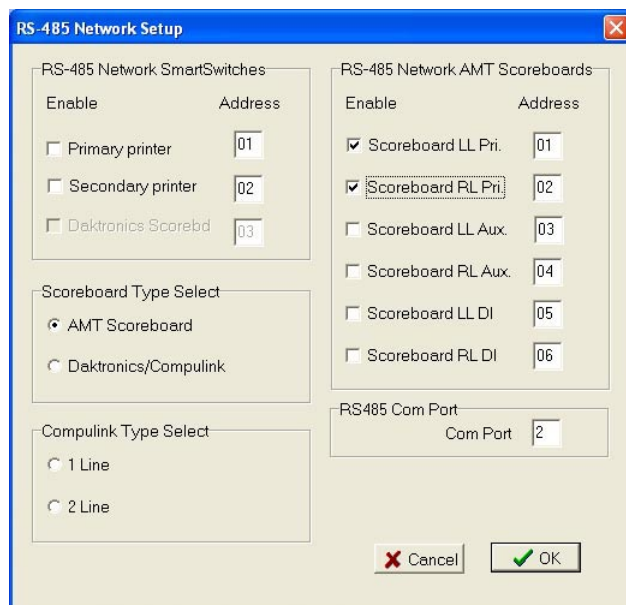

Fig 1 - Network Setup

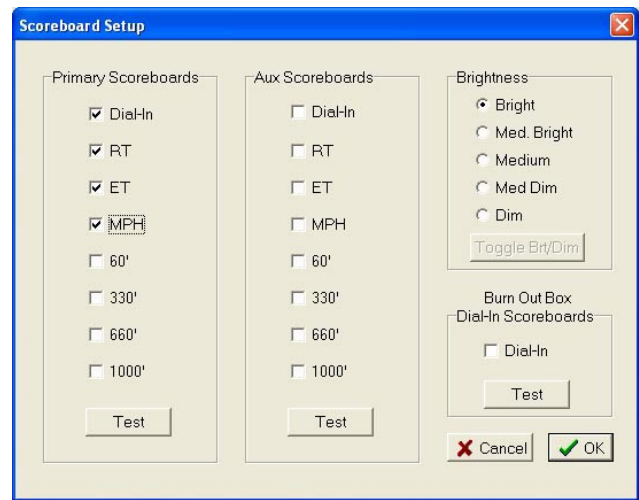

Fig 2 - Scoreboard Setup

completed, the display is ready for use.

POWER-ON SELF-TEST

When the power source is connected, each display unit begins an internal self-test and external visual check of the display elements.

The self-test begins by stepping through each segment of all digits, one segment at a time including the colon or decimal points. The self-test continues by sequentially illuminating each segment until all segments, colons, and decimal points are on. The self-test continues by drawing a square frame by sliding a small square from left to right, then down and right to left. The square then collapses and the revision level of the code running in the microprocessor is displayed. When the internal self-test and external visual test is complete, [rEAdy] scrolls in from left to right and blanks out. The display is now ready for use.

SCOREBOARD OPERATION

Scoreboard operation is controlled by output from the Port-A-Tree Professional software; each scoreboard unit is set to the data display position (eg. Top/Bottom and Left/Right) and will display the data sent by the timing system to the selected position.

See DIP switch settings for the desired race results display.

DIP SWITCH DEFINITIONS

All scoreboard models have two banks of eight DIP switches (S1 and S2) located on the back of the unit numbered from 1 to 8 and can be switched ON or OFF. The ON position is indicated on the switch itself. Each switch function and setting are discussed below.

DIP Switch Bank S1

Port-A-Tree Scoreboard Selection

Switches number 7 and 8 are set as follows:

For scoreboard firmware rev C.x and older

Address	7	8
01	ON	ON
02	ON	OFF
03	OFF	ON
04	OFF	OFF

Switches number 4 and 5 are set as follows:

For scoreboard firmware rev H.x and later

Address	4	5
01	ON	ON
02	ON	OFF
03	OFF	ON
04	OFF	OFF

Diagnostic mode

Switch number 1 enables and disables the diagnostic capabilities of the scoreboard. When enabled, the scoreboard receives data. The following table is used to set switch number 1 to enable/disable the diagnostic feature:

Diagnostic Mode	1
Disabled	ON
Enabled	OFF

DIP Switch Bank S2

Data Interface

Switches number 5 and 6 determine which data interface is used - wireless or hard wired:

Data Interface	5	6
Hard wire	ON	OFF
Wireless Link	OFF	ON

Factory Settings

Other Bank S2 switches should be set as follows:

Switch Number	Status
1	OFF
2	OFF
3	ON
4	ON
7	OFF
8	OFF

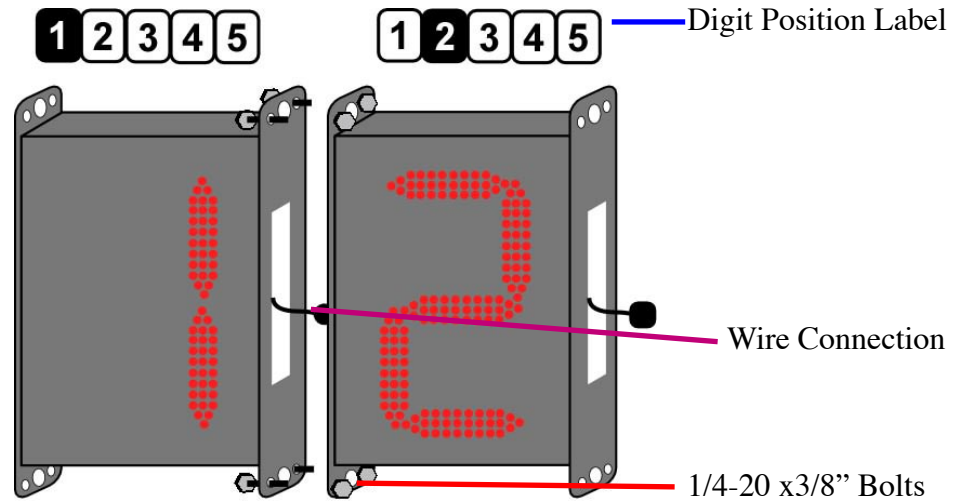

Figure 3 - 24" Cable and unit assembly

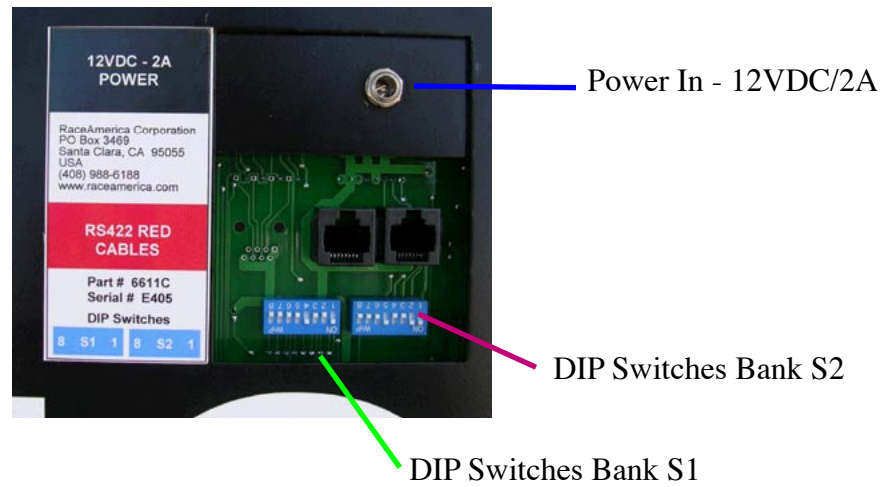

Figure 4 - 15" Scoreboard DIP Switches

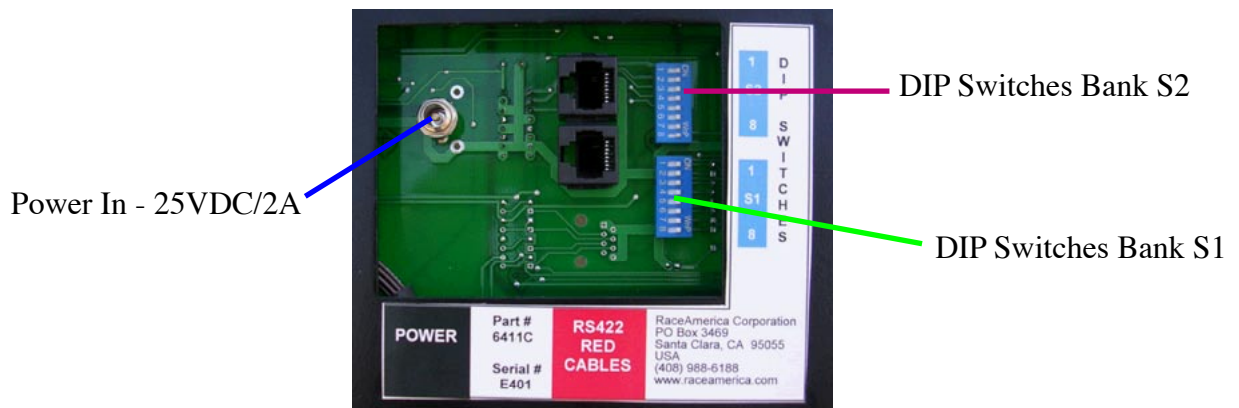
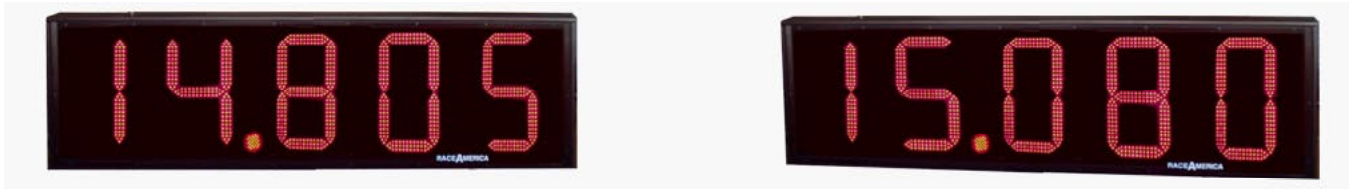

Figure 5 - 24" Scoreboard DIP Switches



6629 Fifteen Inch Single Line Scoreboard

Model 6629 SCOREBOARD

PACKAGE COMPONENTS

- 2 - Scoreboard Units
- 2 - Power Patch Cords
- 4 - Hanger Plates/screws
- 1 - Owner's Manual

Model 6629 Available Options:

- 4520 Wireless Network Links
- 6502A 12V/2A AC Power Adapter-2 req'd
- 6601A Permanent Install Kit

LOCAL REQUIREMENTS

Additional items required to operate the 6629 Single Line Scoreboard and options:

- 1 - 12VDC automotive battery for each unit

Other requirements:

- AC power source for AC adapters

PRODUCT SPECIFICATIONS Model 6629

Display Type:	7-Segment
Digit Size:	15" x 7.75
Number of digits:	Five
Dimensions (half):	64.6"W x 22.3"H x 4"D
Mounting:	Ends 1/4"-20 PEM nuts
Housing:	Powder coated aluminum
View Filter:	Red Transparent acrylic
View Range:	660' in full sun
Power Req't:	11.5 to 12.6VDC/2A x 2
Data Comm:	RS422 serial
Weight (total):	76#

PRODUCT SET-UP

Model 6629 Single Line Scoreboard is designed to hang free using the hanger plates supplied with the scoreboard or mount to a rigid upright pole structure. It is suggested to use the hanging method in windy conditions to avoid damage to the scoreboard and the scoreboard housing.

15" Scoreboard Mounting

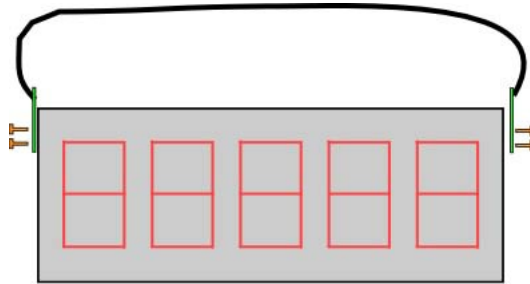

Hanging the 15" scoreboard from the mounting brackets

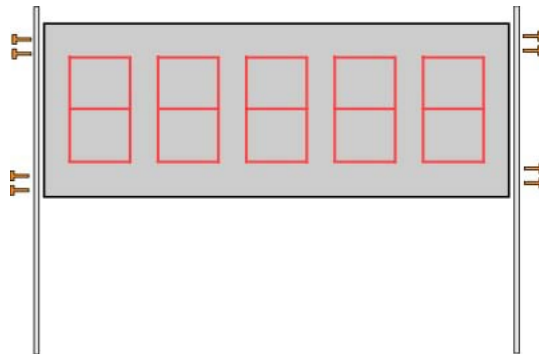

Mounting the 15" scoreboard posts secured to each end.
(1/4-20 PEM nuts on ends)

Figure 4 - Fifteen inch scoreboard mounting



6429 Twenty-four Inch Single Line Scoreboard

Model 6429 SCOREBOARD

PACKAGE COMPONENTS

- 10 - Scoreboard Units
- 1 - Owner's Manual

Model 6429 Available Options:

- 6524A 25VDC/2.5A AC Power Adapter
- 6401A Permanent Installation Kit (includes AC)
- 'W' suffix - Internal Wireless Datacomm link

LOCAL REQUIREMENTS

Additional items required to operate the 6429 Single Line Scoreboard and options:

- 2 - 25VDC/2.5A Power sources
- 2 - Mounting structures

Other requirements:

- AC power source for AC adapters

PRODUCT SPECIFICATIONS Model 6429

Display Type:	7-Segment
Digit Size:	24" x 10"
Number of digits:	Five
Dimensions (half):	113"W x 29"H x 4"D
Mounting:	Top/Btm mounting bolts
Housing:	Powder Coated steel
View Filter:	Red Transparent acrylic
View Range:	1000' in full sun
Power Req't:	25VDC/.2.5A x2
Data Comm:	RS422 serial
Weight (total):	225#

PRODUCT SET-UP

The Model 6429 Single Line Scoreboard is assembled as five individual digits on each side. Mounting bolts hold the individual digits together;

Assemble using the digit position labels located on the top of each digit (segment is identified by the inverse printing of its number). A full unit will have segments one thru five assembled from left to right.

Connect the cable to the connector between each two digits as they are assembled. A horizontal and vertical frame structure is required to mount each scoreboard half (see figure 5).

The 6429 scoreboard must be mounted in a structure for each five digits. This structure can then be hung or secured to the ground.

24" Scoreboard Mounting

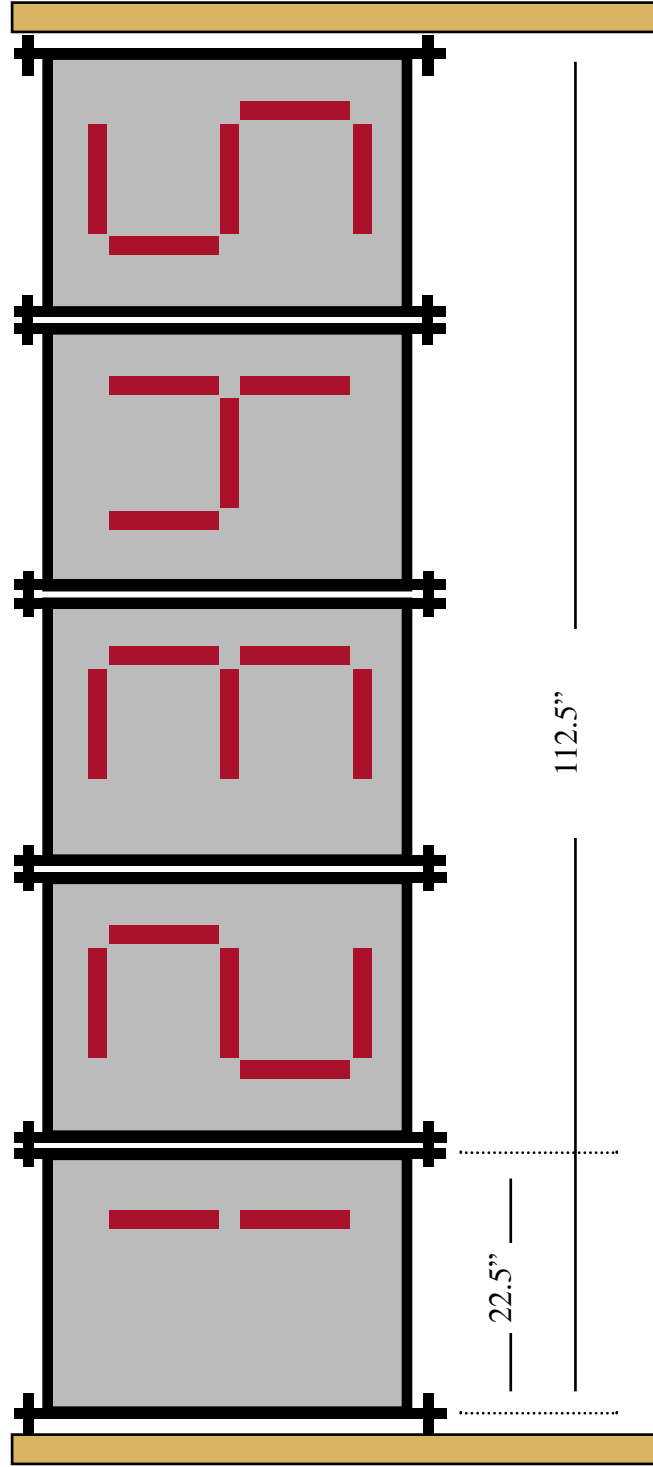

- Each inclosure is 10.2cm (4") deep
- A 15.2cm (6") X 22.9 (9") box projects 5.1cm (2") out from the left for power/data connections
- Bolts at top and bottom secure digits together
- A horizontal brace would nicely secure all digits

Figure 5 - Twenty-four inch scoreboard assembly and mounting

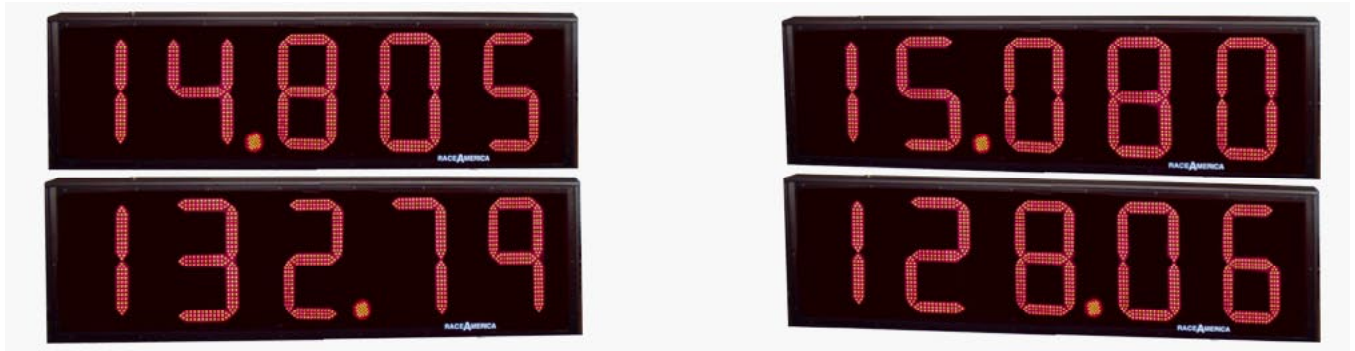

6611 Fifteen Inch Dual Line Scoreboard

Model 6611 SCOREBOARD

PACKAGE COMPONENTS

- 4 - Scoreboard Units
- 8 - Hanger Plates/screws
- 4 - Power Patch Cords
- 1 - Owner's Manual

Model 6611 Available Options:

- 6502A AC Power Adapter - 4 req'd
- 'W' suffix - Internal Wireless Datacomm link
- 6601A Permanent Installation Kit - incl AC

LOCAL REQUIREMENTS

Additional items required to operate the 6611 Dual Line Scoreboard and options:

- 1 - 12VDC auto battery for each two units

Other requirements:

- AC power source for AC adapters

PRODUCT SPECIFICATIONS Model 6611

Display Type:	7-Segment
Digit Size:	15" x 7.75"
Number of digits:	Five
Dimensions (unit):	64.6"W x 22.3"H x 4"D
Mounting:	Hanger plates
Housing:	Powder coated aluminum
View Filter:	Red Transparent acrylic
View Range:	660' in full sun
Power Req't:	12VDC/2A x4
Data Comm:	RS422 serial
Weight (total):	152#

PRODUCT SET-UP

Model 6611 Dual Line Scoreboard is designed to hang from the hanger plates independently or the upper and lower units can be tied together with the hanger plates and hung from the upper plates. The 6611 can also be secured to upright post anchors on both ends. See diagrams for 6629.

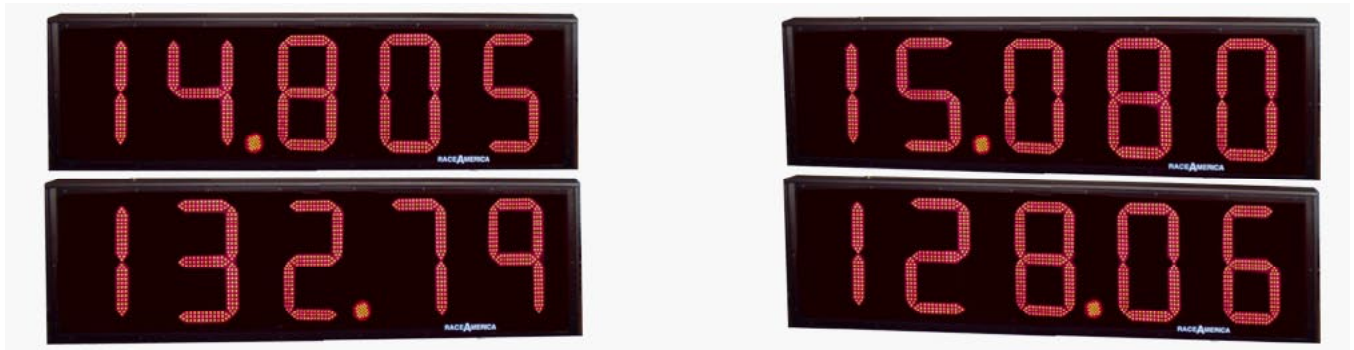

6411 Twenty-four Inch Dual Line Scoreboard

Model 6411 SCOREBOARD

PACKAGE COMPONENTS

20 - Scoreboard Units
1 - Owner's Manual

Model 6411 Available Options:

6524A 25VDC AC Adapter Kit - 4 req'd
'W' suffix - Internal Wireless Datacomm link
6401A Permanent Installation Kit (AC)

LOCAL REQUIREMENTS

Additional items required to operate the 6411 Dual Line Scoreboard and options:

1 - 25VDC source for each unit

Other requirements:

AC power source for AC adapters

PRODUCT SPECIFICATIONS Model 6411

Display Type:	7-Segment
Digit Size:	24" x 10"
Number of digits:	Five
Dimensions (unit):	113"W x 29"H x 4"D
Mounting:	Top/Btm Mounting Bolts
Housing:	Powder Coated steel
View Filter:	Red Transparent acrylic
View Range:	1000' in full sun
Power Req't:	25VDC/2.5A x 4
Data Comm:	RS422 serial
Weight (total):	450#

PRODUCT SET-UP

The Model 6411 Dual Line Scoreboard is assembled as five individual digits on each side. Mounting bolts hold the individual digits together;

Assemble using the digit position labels located on the top of each digit (segment is identified by the inverse printing of its number). A full unit will have segments one thru five assembled from left to right.

Connect the cable to the connector between each two digits as they are assembled. A horizontal and vertical frame structure is required to mount each scoreboard half (see figure 5).

The 6411 scoreboard must be mounted in a structure for each five digits. This structure can then be hung or secured to the ground.

WIRELESS DIAGRAM FOR 15/24in MODELS

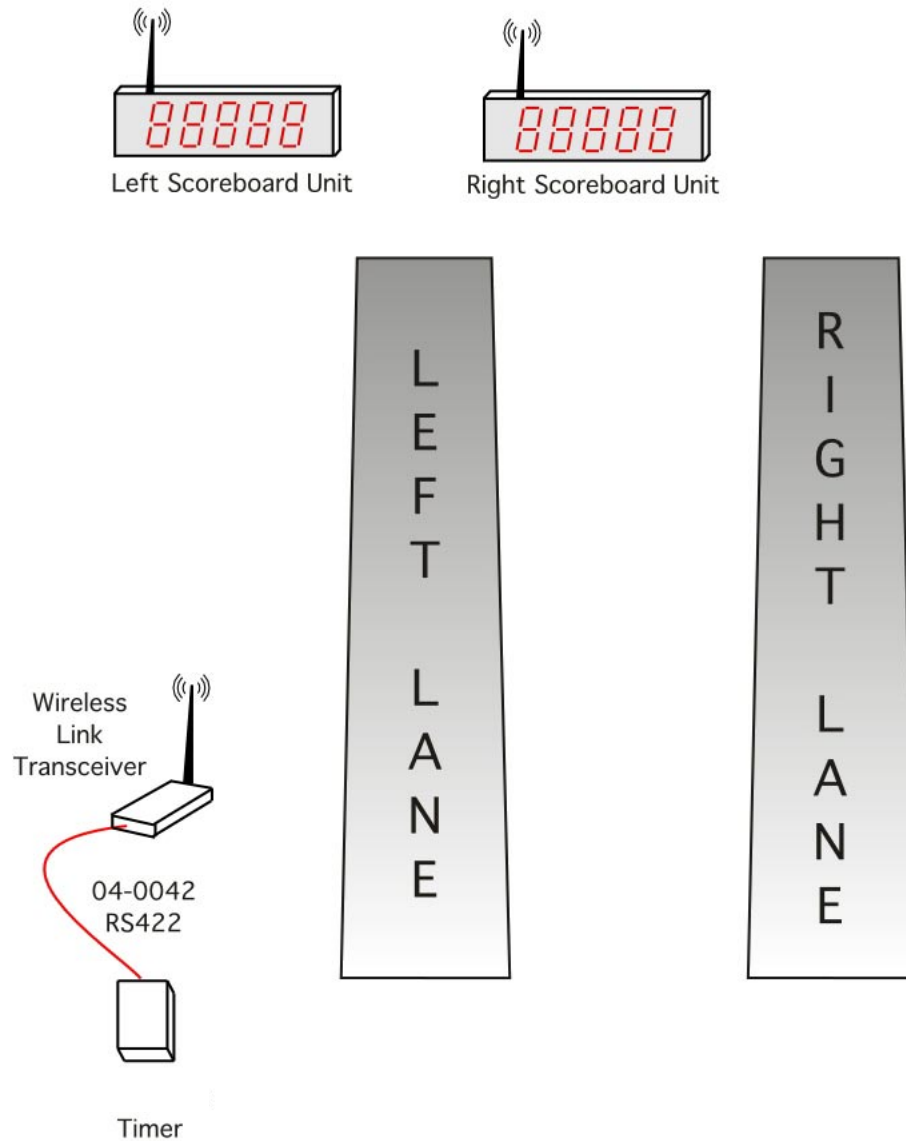

The Left and Right Scoreboards are connected to the Port-A-Tree Gold system wirelessly.

1. Connect the RS422/RS485 cable part number 04-0042 between the Wireless Link Transceiver and the timing system (see cable wiring under SCOREBOARD SET-UP - STEP 3).

Figure 8 - Wireless set-up diagram

SCOREBOARD MAINTENANCE

The drag racing Scoreboards do not require any maintenance to maintain proper operation. If the scoreboard is to be used in rainy or wet conditions, it is suggested to protect the back panel from direct moisture by shielding the connection to power and the serial port.

To clean the red lens, use a non-abrasive cleaner with a soft cloth. This will keep the protective lens clean and maximize visibility and clarity of the digits. If the red lens is soiled with mud or dirt, gently remove the grit using a soft cloth/water being careful not to press when wiping to avoid scratching the red lens acrylic material.

SUPPORT AGREEMENTS

Support agreements are available from RaceAmerica providing Telephone Assistance on technical issues and operational questions, repair and/or replacement of hardware failures, Software and Firmware updates and bug reporting. Contact RaceAmerica for more information and pricing of Support Agreements.