



The Leader in Event Critical Timing Electronics

Model 3800 TIMER AC4



Four Timer Autocross Timing System Owner's Manual

Rev L

**RaceAmerica Corporation
P.O. Box 3469
Santa Clara, CA 95055-3469
USA
(408) 988-6188
<http://www.raceamerica.com>
info@raceamerica.com**

Copyright 2005 RACEAMERICA, Inc.

Table of Contents

LIMITED WARRANTY	3
PACKAGE COMPONENTS.....	4
POWER REQUIREMENTS	4
PRODUCT SPECIFICATIONS.....	4
AVAILABLE OPTIONS	4
THEORY OF OPERATION.....	4
SET-UP STEPS	5
CABLING DIAGRAMS	6
EXTENDED CABLING DIAGRAM USING 4500A COMMUNICATION PODS.....	7
CONSOLE FEATURES.....	8
SAMPLE PRINTOUT FORMATS	8
POWER ON/SELF TEST	9
ALIGNMENT MODE.....	9
SERIAL PORT CONFIGURATION	8
PC MODE OPERATION	10
KEYPAD FUNCTIONS	11
STATUS DISPLAY MESSAGES	12
PRINTER OUTPUT SETUP TABLE.....	14
CHARACTER CODE TABLE.....	15
MAINTENANCE	16
SPARE PARTS.....	16
SUPPORT AGREEMENTS	16
FOAM STAND INSTALLATION.....	17

RACE AMERICA

T i m i n g S y s t e m s

LIMITED WARRANTY

To the original purchaser of this RaceAmerica product, RaceAmerica warrants it to be in good working order for a period of ninety (90) days from the date of purchase from RaceAmerica or an authorized RaceAmerica distributor. Should this product malfunction during the warranty period, RaceAmerica will, at its option, repair or replace it at no charge, provided the product has not been subjected to misuse, abuse, or alterations, modifications, and/or repairs not authorized by RaceAmerica.

Any product requiring Limited Warranty service during the warranty period should be returned to RaceAmerica with proof of purchase. If return of merchandise is by mail, the customer agrees to insure the product, prepay shipping charges, and ship the product to RaceAmerica, Inc., 280 Martin Avenue Unit 1, Santa Clara, CA 95050.

ALL EXPRESSED AND IMPLIED WARRANTIES FOR THIS PRODUCT ARE LIMITED IN DURATION TO THE ABOVE NINETY DAY PERIOD.

UNDER NO CIRCUMSTANCES WILL RACEAMERICA BE LIABLE TO THE USER FOR DAMAGES, INCLUDING ANY LOST PROFITS, LOST SAVINGS, OR OTHER INCIDENTAL OR CONSEQUENTIAL DAMAGES ARISING OUT OF THE USE OF, OR INABILITY TO USE, SUCH PRODUCT.

THIS WARRANTY GIVES YOU SPECIFIC LEGAL RIGHTS, AND YOU MAY ALSO HAVE OTHER RIGHTS WHICH MAY VARY FROM STATE TO STATE.

PACKAGE COMPONENTS

Each TIMER AC4 Autocross package includes:

- 1 - 3800D TIMER AC4 Console Unit
- 2 - IR Beam Emitters (5040B)
- 2 - IR Track Sensors (5140D)
- 2 - Track Sensor Cables - 100ft each
- 1 - Owners Manual

POWER REQUIREMENTS

You will need these additional items to operate your TIMER AC4

- 1 - 12VDC automotive battery
- 8 - AA Alkaline batteries (for emitters)

PRODUCT SPECIFICATIONS

The following listing provides the designed performance specifications for the Model 3800 TIMER AC4:

Start/Finish Lane Width	4 to 50 Feet
Timer Capacity	up to 9:59.999 or 999.999 sec
Time Accuracy	0.001 seconds

Power Requirements:

3800D Console	12VDC 3A
IR Beam Emitters	8 - AA Batteries

Model 3800 AVAILABLE OPTIONS

- 7540B Foam Stands
- 6038S Dot-Matrix Timeslip Printer Package
- 6560/6860 Large Digital Display
- 4500B Data Communication PODs (for printers and displays greater than 100ft from console)
- 4520/4620 Wireless RF Data Links
- 6070B Carry/Storage Case
- 6502A AC Power Adapter (for timer)
- 5050B Extended range Beam Emitter - 75 ft
- 5060A Extended range Beam Emitter - 250 ft

THEORY OF OPERATION

The Model 3800 TIMER AC4 is a completely self contained race timing system made with the latest technology CMOS circuit components to provide a highly accurate autocross timing solution. The system contains an internal quartz crystal clock to maintain time accuracy and display of race results to one thousandth of a second.

Power is supplied to the timer console and track sensor components of the 3800 TIMER AC4 by the 12VDC automotive battery or regulated DC power source connected to the RED and BLACK alligator clips. An absolute minimum of 9.0VDC is required for reliable operation of the system. Under normal conditions, a properly charged battery will operate for an entire day of racing without requiring a recharge.

The Beam Emitters and Track Sensors operate on invisible (to the unaided human eye) Infra Red light. The coded light frequencies are constantly received by the Track Sensors until a car interrupts reception ('breaks' the beam).

The IR Beam Emitter to Track Sensor transmission operates on Line-of-Sight principles. This makes alignment of these units critical. Tips are provided to aid alignment on surfaces that are other than ideal. These units will operate over a wide range of conditions but should not be operated beyond the specification parameters (less than 4 ft or more than 50 ft).

Once the system is properly set up and aligned on the racing surface, the timer console will continue to 'monitor' the track sensor at the start line to start the next timer or at the finish line to stop the next timer.

NOTE: once the start or finish line beam is interrupted, the system imposes a 5-second lockout of that sensor to allow blowing debris to settle. During the last second of the 5-second lockout, the system performs alignment testing of the triggered sensor to determine if the alignment has changed. Failure of the starting line beam alignment is indicated with [SbAd]. [FbAd]

would indicate the finish line alignment has failed testing. These messages are displayed until another message updates the Status Display. This feature helps in early detection and resolution of a low battery in the Beam Emitters, someone tripped over a cable, or a sensor has been bumped out of alignment.

NOTE: Once all four timers are actively counting, any additional interruption of the start line beam will not start a new timer until one of the current timers is stopped by a finish line crossing or manually stopped via the keypad.

SET-UP STEPS - TIMER AC4

STEP 1 -

Familiarize yourself with the Components pictured in this manual and how they interconnect. The Track Sensor Interconnect Cable is configured for connection between the starting line, the finish line and the timer console.

All connectors are keyed for proper orientation. The 12VDC battery is connected with the RED alligator clip to plus (+) terminal of the battery and the BLACK alligator clip to (-) terminal of the battery.

The free standing, battery powered Model 5040A IR Beam Emitters are placed on the one side of the start line and finish line and the Model 5140C IR Track Sensors are placed on the other side of the start line and finish line. Each of the Beam Emitter and Track Sensor units are fully interchangeable with each other. The Track Sensor Interconnect Cable is keyed to match the start line and finish line track sensor, position identified at the track sensor end of the cable.

STEP 2 -

Identify the emitter/sensor placement at the start line and finish line. The lane width should be set between four (4) and fifty(50) feet. To help in determining initial Beam Emitter to Track Sensor alignment in larger track widths, use a string stretched between the beam emitter and track sensor or eyeball a straight line between units.



Model 5040/5050 - IR Beam Emitter

Note On/Off switch and placement for four AA batteries for each Beam Emitter. All Beam Emitters are fully interchangeable with one another. Picture shows top and bottom of units.



Model 5140 - IR Track Sensor

Note cable connector is located in the side facing away from the track. All Track Sensor are fully interchangeable with one another. Track Sensor is pictured both top and bottom sides up.

STEP 3 -

Layout the interconnect cable on the track site. The large connector (RJ45) connects to the console and the smaller connectors (RJ11) connect to the Track Sensors at the start line or the finish line.. Connect the two Interconnect Cables to the Timer Console and the Track Sensors.

STEP 4 -

Connect the RED and BLACK alligator clips to the 12VDC battery and you're ready to begin.

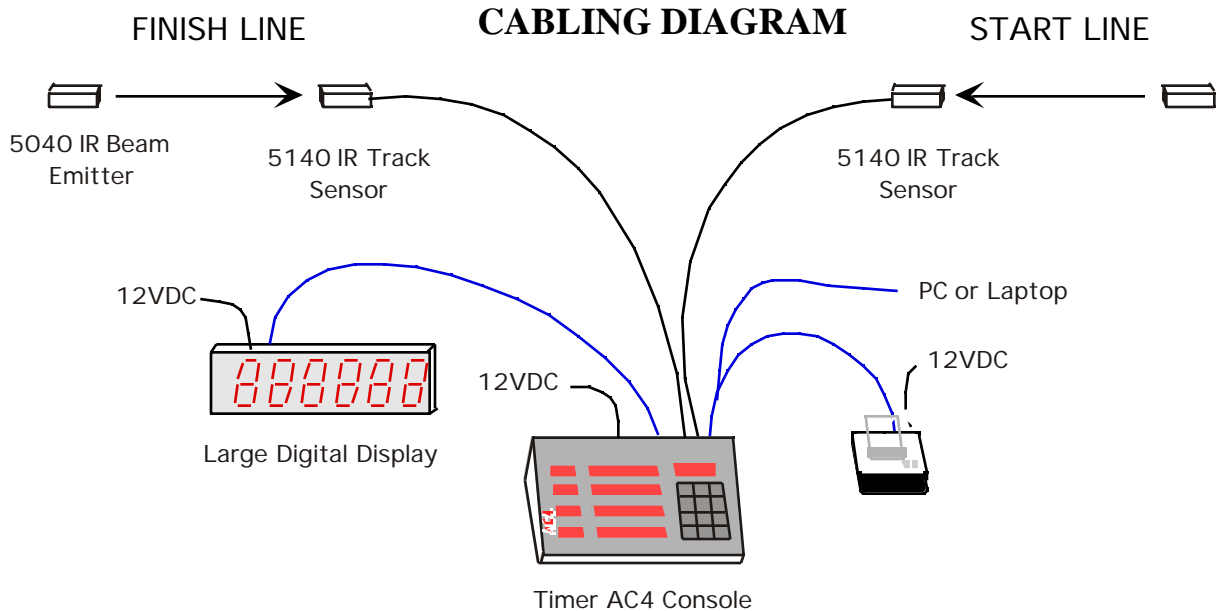

IR Track Sensors at the Start & Finish lines connect to the respective TRACK SENSOR ports using individual cables.

The Large Digital Display connects to the DIGITAL DISPLAY port using a 25ft or 100ft 06-X100 display cable.

The Printer connects to the RS232 SERIAL PORT using a proprietary interface cable; a PC connects to the RS232 SERIAL PORT using a 06-PC02.

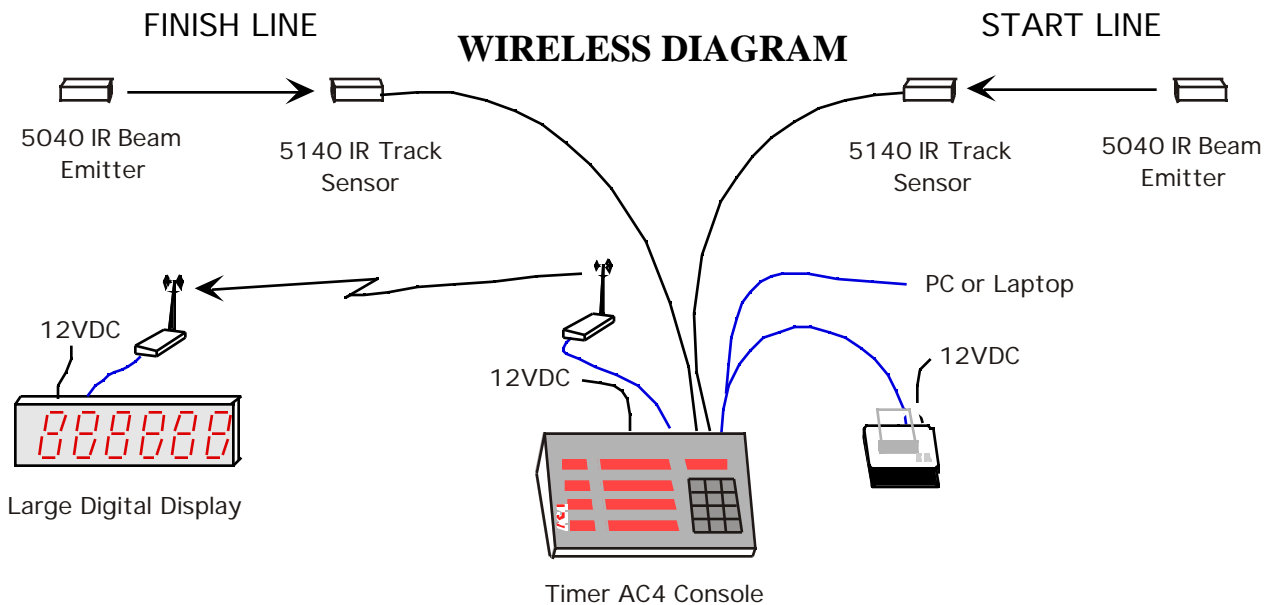

IR Track Sensors at the Start & Finish lines connect to the respective TRACK SENSOR ports using individual cables.

The Large Digital Display connects to the DIGITAL DISPLAY port using 4520 Wireless RF Link Units. 07-4554 cables connect Wireless Links to each device; power is supplied by the device.

The Printer connects to the RS232 SERIAL PORT using a proprietary interface cable; a PC connects to the RS232 SERIAL PORT using a 06-PC02. A Wireless connection can be made to the printer or PC also.

EXTENDED CABLING DIAGRAM USING 4500A COMMUNICATION PODS

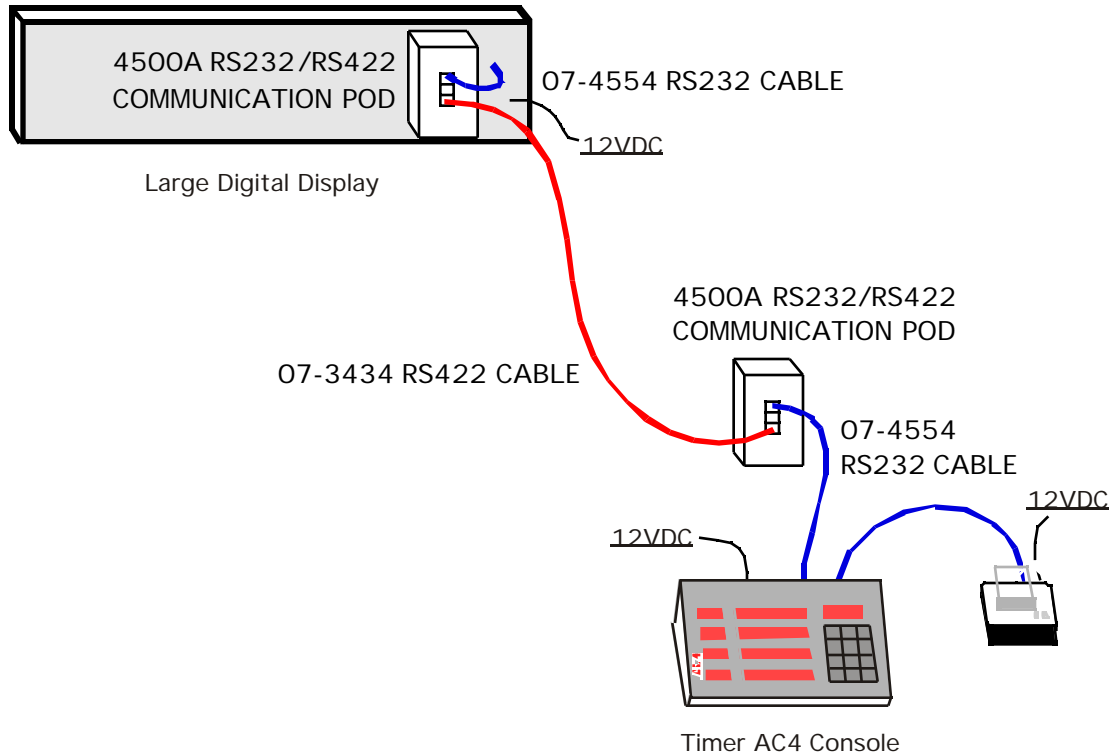

To extend the cable lengths between the Timer AC4 and the Large Digital Display beyond the 100 foot limit, model 4500A RS232/RS422 Communication PODs are added. Connections between the Timer AC4 and the Large Digital Display are as follows:

1. Place the 4500A POD to the back of the Large Digital Display using the Velcro backing materials attached to the POD and the display. Connect the loose end of the 07-4554 RS232 cable to the connector on the back of the display.
2. Connect the POD with the 5 foot long 07-4554 RS232 Cable to the Timer AC4's LARGE DISPLAY jack.
3. Connect the 07-3434 RS422 cable to each 4500A POD by plugging into either of the RS422 jacks.
4. When the Timer AC4 is powered up, the RECV and XMIT LEDs on the 4500A POD will illuminate. When power is applied to the Large Digital Display, the RECV LED on the 4500A POD will illuminate. During transmission, the XMIT LED will flash on the pod connected to the AC4, the RECV LED will flash on the POD connected to the Large Digital Display.

Wireless Link Units will eliminate the PODs and red interconnect cable as show in the previous page. 7

CONSOLE FEATURES

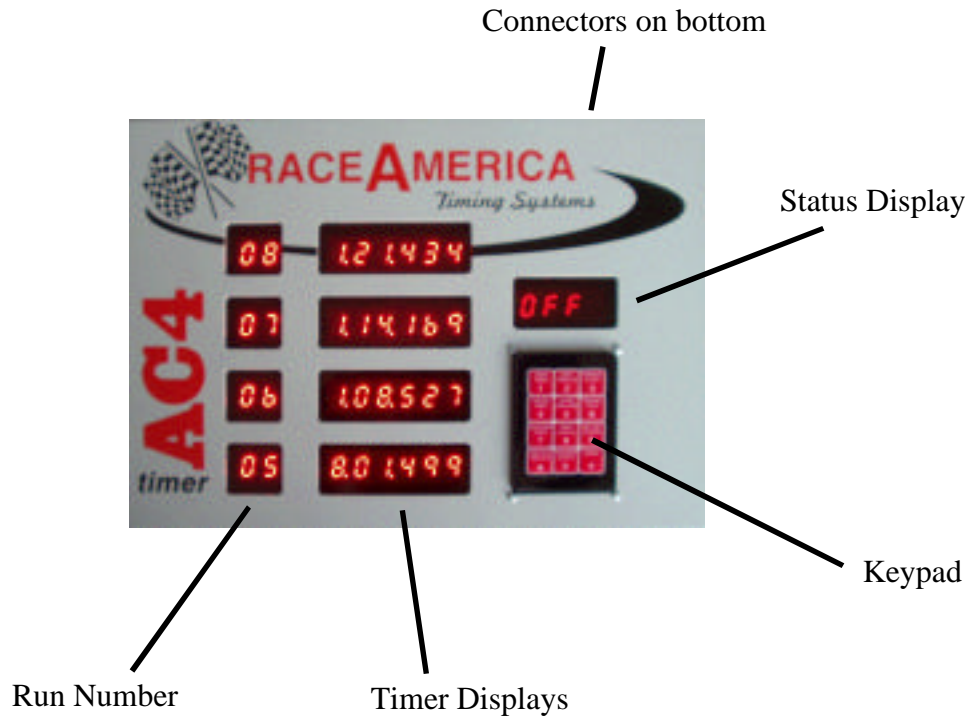

The Timer AC4 Console contains a Status Display for display of the current mode of operation of the timer, confirm detection of a car by the Track Sensors, and verification of timeslip header and Emitter/Sensor alignment.

Each of the four timers are assigned a Run Number at the start of each run indicated on the left side of the console. The elapsed time associated with each run is indicated in each of the four Timer Displays in the center of the console. The keypad is used to enter timeslip header information and control all functions of the timer.

SAMPLE PRINTOUT FORMATS

(shown in minutes:seconds.fraction time display)

Data Logging Format

Autocross Timer AC4	
Run	Time
04	2:20.491
05	2:24.405
06	2:19.006

Timeslip Format

Autocross Timer AC4	
Run 05	Time 2:20.491
RACEAMERICA Timers	

POWER ON/SELF-TEST

Connecting the 12VDC battery places the RaceAmerica TIMER AC4 into a self-test of the microprocessor circuitry and LED displays (Light Emitting Diode). This is an internal test as well as a visual check of each display. The Status Display sequences through each segment of all four digits, then illuminates each segment and decimal point of all four digits until the number 8 is illuminated with the decimal point. The LED Display then places an 8 with decimal point in the far right digit and shifts the display to the left through all four digits.

The Run Number displays and the Timer displays then sequence through 0 through 9, blank out, then reset to the initial timer setting of 0.000 seconds.

The Status Display then sequences through the PRODUCT number and the CODE revision level contained within the computer.

ALIGNMENT MODE

To verify all Track Sensors are properly aligned with their Beam Emitters, the Status Display enters into the Alignment Mode immediately after the power on selftest or when the operator selects the Alignment Mode by pressing the **[5]** key on the Keypad with the Track Sensors disabled (this is covered later in these instructions). The Status Display momentarily indicates the position on each sensor on the display with letters represent each emitter/sensor pair **[S-F]**. The **[S]** indicates the START emitter/sensor pair, the **[F]** indicates the FINISH line emitter/sensor pair. The Status Display then changes each digit to a zero for each sensor being monitored **[0--0]**. If the Beam Emitter and Track Sensor are operating properly and aligned, the 0 digit will not change. If the Beam Emitter and Track Sensor are not properly aligned, the 0 digit for each emitter/sensor pair will count slowly if slightly out of alignment or continuously if they are not functioning properly or way out of alignment.

Once the emitter/sensor pair are aligned properly, the digit will stop counting. If the alignment is off a little or intermittent, the digit for that emitter/sensor pair will count when they float out of alignment. Remember, the Beam Emitters and Track Sensors operate on a 'Line-of-Sight' concept and may require shims if they are installed on a street with a crown. Leaves, people, and other debris will also break the beams and could give false signals, so keep everyone and everything clear of the Beam Emitters and Track Sensor during racing activity.

To maximize the alignment of the emitter/sensor pairs, it is suggested to rotate the Beam Emitter slowly left and right until the alignment for that pair begins to count. This technique will determine the maximum lateral detection angle. Rotating the Beam Emitter up and down until the alignment starts counting determines the maximum vertical detection angle. Once these extremes are established, position the Beam Emitter in the center of the left/right detection angle and up/down detection angle. Repeat this same process with the other Beam Emitter and both Track Sensors. This will maximize the alignment accuracy. Press the **[#]** pound sign key to exit Alignment Mode.

SERIAL PORT CONFIGURATION

The RS232 Serial Port can be configured for a printer or to interface to a PC running race management software. There are two printout formats available standard with the Timer AC4, a Timeslip format and a Data Logging format. The Status Display will enter the Print Format Mode indicated by **[HEAd]**. The Status Display will indicate **[PC]** to select PC mode. Pressing the **[#]** pound sign key will select the RS232 Serial Communications Port to be used in PC mode to interface to a PC running race management software. Pressing any other key will toggle the selection back to the Timeslip format selection. The Status Display will indicate **[SLiP]** to enable the operator to select the Timeslip format for the printer by pressing the **[#]** pound sign key.

Pressing any other key will toggle the selection to Data Logging format as indicated by [Log] in the Status Display. Pressing the [#] pound sign key will select the Data Logging format for the printer. Pressing any other key will toggle the selection back to PC mode selection.

If the [#] pound sign key was pressed to select a printer output format, a sample timeslip or data logging header will be printed. If the [#] pound sign key was pressed to use the RS232 Serial Port for connection to a PC, a signal is sent from Timer AC4 to the PC to let the PC software know the timer is ready to time the first car. This same data is sent to the Digital Display port and any connected six digit Digital Displays should display X:XX.XXX or XXX.XXX. A four digit display will show X.XXX (only operated in SSS.FFF display format).

NOTE: When connecting to the Serial Port, the printer or PC must be configured at 9600 baud, 8 data bits, no parity, 1 stop bit, no handshake (9600/8/N/1).

PC MODE OPERATION

Timer AC4 is designed to interface with third party race management software. The timer sends signals to the PC when Timer AC4 enters PC mode, the Timer AC4 Console is stopped or cleared, cars break the start or finish line beams, a timer is restarted or continued, and when the sensors are enabled and disabled. The following communication strings are sent to the PC on each event:

Enter PC mode:	[hexF0][cr][lf]
Console stopped:	[hexF0][cr][lf]
Console cleared:	[hexF0][cr][lf]
Car starts:	[hex90][cr][lf]
Car finishes:	[hex80]fffsss[cr][lf]
or	[hex80]ffssm[cr][lf]
A timer is restarted:	[hexA0][cr][lf]
Sensors are disabled:	[hexB0][cr][lf]
Sensors are enabled:	[hexC0][cr][lf]

KEYPAD FUNCTIONS



KEY 0

The [0] key is used to enable (on) and disable (off) the detection of cars by the Track Sensors. The Status Display will indicate the sensors are on [SnSr][on] or off [SnSr][OFF] and must be off to use functions [2], [5], and [8]. Attempting to access functions [2], [5], and [8] with the sensors enabled will cause the Status Display to display the message [SnSr][on] and abort the function. Pressing the [0] key repeatedly will toggle the sensors on and off.

NOTE: when the sensors are off, they will not detect any cars crossing the starting line or the finish line. As a reminder to the operator, [OFF] will be displayed in the Status Display when the sensors are disabled and no other function is being used.

KEY 1

Pressing [1] on the keypad will halt all currently counting timers. This is convenient when something happens on the track requiring a restart of all cars being actively timed. The next run will be assigned the next Run Number when the start beam is interrupted.

KEY 2

See **PRINTER OUTPUT SETUP TABLE** for instructions on the use of the [2] key to edit the 20-character timeslip header.

KEY 3

Pressing the [3] key will manually start a timer. This is the same function as breaking the start beam. If all four timers are counting and the [3] key is pressed, the bottom timer will be lost and a new timer will be started at the top of the display. Since this is manual mode, the operator has full control of the timer starting function.

KEY 4

Pressing the [4] key halts all timers, resets all four timers back to **0.000** seconds, clears the run numbers, and resets the next run number to **01**. This function is used to completely reset the Timer AC4 back to its initial startup point.

KEY 5

To enter alignment mode, the sensors must first be disabled (turned off). This is accomplished by pressing the [0] key and viewing [SnSr][OFF] in the Status Display. The [5] key is then pressed to enter alignment mode. See the section on **ALIGNMENT MODE** earlier in this manual.

KEY 6

To manually stop the next timer, press the [6] key. This is the same function as a car crossing the finish line and blocking the beam.

KEY 7

If a timer is inadvertently stopped by a worker running through the finish line or manually stopped by pressing the Manual Stop or Off Course keys, the timer can be restored and counting with the correct elapsed time using the [7] Continue key. The most recently stopped timer is restarted and updated from a backup timer internally maintained by the Timer AC4. The timer is restarted and updated with the correct elapsed time. When the timer is stopped again, the run results will be sent again to the printer with the current elapsed time. A timer can be stopped and restarted an unlimited number of times.

NOTE: All four timers also have a backup timer internally maintained by Timer AC4. These free-running timers do not stop at the maximum elapsed time, instead, the timers roll over back to zero and continue to count. Care should be taken if a long period of time elapses between when the timer was stopped and restarted.

KEY 8

See **PRINTER OUTPUT SETUP TABLE** for instructions and use of the [8] key for printing timeslips.

KEY 9

If a car does not complete the course and their time is no longer valid, wait until their timer is the next timer to stop. Pressing the [9] key will stop the next timer (same as the car crossing the finish line) and update the timer with the maximum elapsed time to indicate the car went Off Course and the time is invalid. The maximum value will be 9:59.999 or 999.999 seconds dependent upon the Timer AC4 display format ordered. This is also the time value printed on the timeslip.

STATUS DISPLAY MESSAGES

During normal operation, messages will appear in the Status Display. These messages indicate status, mode of operation, or events occurring on the race track. Many of these messages are covered elsewhere in this manual and are alphabetically summarized in the following section as a reference:

Align S--F

When entering Alignment Mode, these messages will appear in sequence to indicate the alignment of the Track Sensors and Beam Emitters will be continuously monitored and the results displayed.

CLr

This message confirms all timers have been stopped, reset to 0.000 seconds, and run numbers have been reset to start with 01. The Timer AC4 is ready for the next run.

Code

This message appears during the power-up sequence and indicates the software code level running in the RACEAMERICA timer.

Cont

When a timer is restored after being stopped by mistake, this message appears momentarily to confirm the timer is being restarted

End

This messages indicates the stopping of a timer. It will appear every time the finish line beam is interrupted by a car or the manual stop key is pressed on the keypad. The timer in the Timer Display currently counting with the highest time elapsed is stopped and output is sent to the printer.

Edit

This message will appear momentarily when entering the Edit Timeslip Mode. It confirms the keypress by the operator.

FbAd

This message indicates the alignment of the Track Sensor and Beam Emitter at the finish line has failed to maintain alignment while the Timer AC4 was performing realtime testing after a car passed through the finish line beam. This message will disappear when another message is displayed in the Status Display. It will appear each time the finish line alignment is detected as bad.

HEAd

During power-up of the Timer AC4, the operator is prompted for the print format. This message is displayed momentarily as the operator enters into the Print Format Mode to select the format of race results sent to the printer after every run.

Log

During power-up of the Timer AC4, the operator is prompted for the print format. This message indicates run results Data Logging format will be selected by pressing the ‘#’ key.

OFF

This message will keep appearing if the sensors have been disabled by the operator. This message is a reminder to enable the sensors prior to the start of the race event in order to detect cars at the start and finish lines.

Out

This message will appear when the operator determines a car has strayed off course and the respective timer in the Timer Display is no longer valid. The timer in the Timer Display currently counting with the highest time elapsed is stopped, set to the maximum time value, and output is sent to the printer.

PC

During power-up of the Timer AC4, the operator is prompted for the use of the RS232 Serial port. This message indicates the PC mode will be selected by pressing the ‘#’ key.

Prod

This message appears during the power-up sequence and indicates the product number of the RACEAMERICA timer.

Prnt

This message will appear when the operator is manually printing a timeslip to verify the timeslip header after entry. The message indicates the Timer AC4 is busy outputting a timeslip to the printer.

SbAd

This message indicates the alignment of the Track Sensor and Beam Emitter at the start line has failed to maintain alignment while the Timer AC4 was performing realtime testing after a car passed through the start line beam. This message

will disappear when another message is displayed in the Status Display. It will appear each time the start line alignment is detected as bad.

SLiP

During power-up of the Timer AC4, the operator is prompted for the print format. This message indicates run results Timeslip format will be selected by pressing the ‘#’ key.

Sn

This message appears during the power-up sequence and indicates the serial number of the RACEAMERICA timer.

SnSr OFF

These messages will appear in sequence to confirm the sensors have been disabled by the operator.

SnSr on

These messages will appear in sequence when the sensors have been enabled by the operator or the operator is attempting to enter a mode of operation requiring the sensors to be disabled (off) prior to the Timer AC4 entering the requested mode of operation.

StoP

This message confirms all timers have been stopped and are ready for the next run to begin with the next run number.

Strt

This message indicates the starting of a new timer. It will appear every time the starting line beam is interrupted by a car or the manual start key is pressed on the keypad. The four timers in the Timer Display are rotated downward. The topmost timer of the Timer Display is reset to zero and starts counting.

PRINTER OUTPUT SETUP TABLE

Character Position	01	02	03	04	05	06	07	08	09	10	11	12	13	14	15	16	17	18	19	20
Display Character																				
Character Code																				

Character Position	01	02	03	04	05	06	07	08	09	10	11	12	13	14	15	16	17	18	19	20
Display Character																				
Character Code																				

STEP 1 - Select the 20 characters to be used as the timeslip header. Enter the characters in one of the Setup Tables above. To center the heading, place blank spaces before and after the characters to be printed. The power-on default timeslip header is **Autocross Timer AC4** and will be replaced by your input until the TIMER AC4 is powered off.

STEP 2 - Using the Character Code Table on the next page, find the character code for each of the 20 characters. All printable characters are listed in the Character Code Table. Remember to enter the code for a blank space between words as code 00.

STEP 3 - Disable the Sensors by pressing [0] on the keypad. The Status Display will confirm the state of the sensors with [SnSr][OFF].

STEP 4 - Enter the Edit Timeslip Header Mode by pressing [2]. The Status display confirms by displaying [Edit].

STEP 5 - The Status Display places 4 digits in the display. The left two digits represent the character position of the above Setup Table. The right two digits represent the character code of the current character of the timeslip. To change the character, enter the two digit number on the keypad. Press [#] the pound sign to save your input for that character. The Status Display will increment the left two digits to the next character position and the right two digits to the character code of the current printing character. Continue editing until all 20 characters have been entered. Press [*] the asterick key to exit Edit Mode.

STEP 6 - Press [8] to print a timeslip to verify everything was entered correctly.

STEP 7 - Remember to enable the Track Sensors by pressing [0] and viewing [SnSr][on] in the Status Display.

CHARACTER CODE TABLE

Character	Code	Character	Code
Space	00	P	48
!	01	Q	49
@	02	R	50
#	03	S	51
\$	04	T	52
%	05	U	53
&	06	V	54
'	07	W	55
(08	X	56
)	09	Y	57
*	10	Z	58
+	11	[59
'	12	v	60
-	13		61
.	14]	62
/	15	—	63
0	16	‘	64
1	17	a	65
2	18	b	66
3	19	c	67
4	20	d	68
5	21	e	69
6	22	f	70
7	23	g	71
8	24	h	72
9	25	i	73
:	26	j	74
;	27	k	75
<	28	l	76
=	29	m	77
>	30	n	78
?	31	o	79
@	32	p	80
A	33	q	81
B	34	r	82
C	35	s	83
D	36	t	84
E	37	u	85
F	38	v	86
G	39	w	87
H	40	x	88
I	41	y	89
J	42	z	90
K	43	{	91
L	44		92
M	45	}	93
N	46	~	94
O	47		

MAINTENANCE

The Model 3800 TIMER AC4 Console, Beam Emitters, and Track Sensors do not require any maintenance.

To insure uninterrupted operation on raceday, it is suggested to keep track of battery usage hours so as to have fully charged batteries. Plan to replace the alkaline AA cells in the Beam Emitters after about 60 hours use. If you are using rechargeable AA cells, recharge them each day. Low battery voltage (Emitters below 4.0V DC) will cause intermittent operation of the system resulting in intermittent cars detected at the starting line or the finish line as the batteries power weakens.

To maintain the highest level of timing accuracy and minimize false trips, annual preventative maintenance and calibration should be performed on all system track sensors and beam emitter units.

SPARE PARTS

Further to minimize race program interruptions, RaceAmerica recommends some spare parts. A spare emitter/sensor pair and sensor cable should be available in the event of an unfortunate accident during a program. Contact RaceAmerica for availability and pricing of spares items.

SUPPORT AGREEMENTS

Support agreements are available from RaceAmerica providing Telephone Assistance on technical issues and operational questions, repair and/or replacement of hardware failures, Software and Firmware updates and bug reporting, and Annual Preventative Maintenance on all system track sensors and beam emitter units. Contact RaceAmerica for more information and pricing of Support Agreements.

7540B - Foam Stand Assembly Instructions

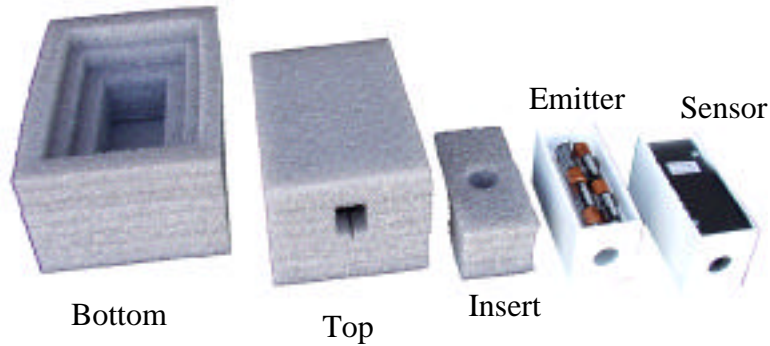

'AA' Battery Emitter & Sensor Installation:

1. Separate the Bottom of the Foam Stand from the Top.
2. Remove the Insert from the Top.
3. Place the 5040A Emitter or 5140C Sensor into the upper half with the bottom side showing. Install batteries and turn on the Emitter.
4. Replace the Insert into the Top. Connect the cable to the Sensor
5. Insert the Top into the Bottom. Place on the track



Installing an Emitter
Similar for Sensor

5042A Emitter:

1. Same as above except place the 'C' Battery pack in the Bottom and connect the wire to the Emitter.



5042A Emitter

Additional Stability - add weight to the Bottom

1. Place a weight into the Bottom well.



Complete Installation