



The Leader in Event Critical Timing Electronics



*2700 Series
XL Wireless
Drag Race
Timing System
Owner's Manual*

Rev G

RaceAmerica Corporation
P.O. Box 3469
Santa Clara, CA 95055-3469
(408) 988-6188
<http://www.raceamerica.com>
info@raceamerica.com

Copyright 2009 RaceAmerica Corporation

Table of Contents

LIMITED WARRANTY	3
THEORY OF OPERATION	4
QUICK START GUIDE	5
PACKAGE COMPONENTS	6
AVAILABLE OPTIONS.....	6
LOCAL REQUIREMENTS.....	7
PRODUCT SPECIFICATIONS	7
TRACK SENSOR and BEAM EMITTER OPERATION.....	7
WIRELESS OPERATION.....	9
SET-UP STEPS - 2700 SERIES	10
TREE ASSEMBLY	12
TRACK LAYOUT - SENSORS/CABLING DIAGRAM	14
KEYPAD FUNCTION.....	15
NAVIGATING TIMER MENUS.....	15
DEFINITIONS of the TREE LIGHTS	16
POWER ON/SELF TEST	16
BACKGROUND MONITORING.....	17
SINGLE or DUAL LANE OPERATION.....	18
DIAGNOSTICS MENU	
Sensor Alignment	18
Battery Level	20
RF Integrity	20
SYSTEM MENU	
Sensor Test	20
Timeslip Printer	20
Speed Trap.....	20
Custom Print Header.....	21
CONFIGURE MENU	
Tree	21
Display.....	22
Race	22
RUNNING A RACE.....	22
TIME of DAY& COUNTDOWN FUNCTIONS	24
KEYPAD FUNCTIONS	25
STATUS DISPLAY MESSAGES.....	26
TROUBLE SHOOTING	27
CONNECTING PERIPHERAL DEVICES	28
RACE MANAGEMENT SOFTWARE.....	28
WIRELESS FIRMWARE UPDATE.....	28
MAINTENANCE.....	29
SPARE PARTS	29
SUPPORT AGREEMENTS.....	29
TIMESLIP HEADER WORKSHEET	30
FOAM STAND ASSEMBLY.....	32

RACE AMERICATM

T i m i n g S y s t e m s

LIMITED WARRANTY

To the original purchaser of this RaceAmerica product, RaceAmerica warrants it to be in good working order for a period of ninety (90) days from the date of purchase from RaceAmerica or an authorized RaceAmerica distributor. Should this product malfunction during the warranty period, RaceAmerica will, at its option, repair or replace it at no charge, provided the product has not been subjected to misuse, abuse, or alterations, modifications, and/or repairs not authorized by RaceAmerica.

Any product requiring Limited Warranty service during the warranty period should be returned to RaceAmerica with proof of purchase. If return of merchandise is by mail, the customer agrees to insure the product, prepay shipping charges, and ship the product to RaceAmerica, Inc., 280 Martin Avenue Unit 1, Santa Clara, CA 95050.

ALL EXPRESSED AND IMPLIED WARRANTIES FOR THIS PRODUCT ARE LIMITED IN DURATION TO THE ABOVE NINETY DAY PERIOD.

UNDER NO CIRCUMSTANCES WILL RACEAMERICA BE LIABLE TO THE USER FOR DAMAGES, INCLUDING ANY LOST PROFITS, LOST SAVINGS, OR OTHER INCIDENTAL OR CONSEQUENTIAL DAMAGES ARISING OUT OF THE USE OF, OR INABILITY TO USE, SUCH PRODUCT.

THIS WARRANTY GIVES YOU SPECIFIC LEGAL RIGHTS, AND YOU MAY ALSO HAVE OTHER RIGHTS WHICH MAY VARY FROM STATE TO STATE.

THEORY OF OPERATION

The 2700 Series Drag Timers are dual microprocessor controlled completely self-contained race timing systems utilizing the latest CMOS technology circuit components to provide a highly accurate wireless drag timing solution. The system contains internal quartz crystal clocks to maintain time accuracy and display of race results to one thousandth of a second (0.001 sec) and multiple microprocessors to manage the data collected on the track.

The wireless data management of the system represents a true break through in race timing methodology. RaceAmerica uses proprietary technology blended with industrial grade wireless technology to give ease of use and accuracy. Each sensor trip (beam break) is retained locally and transmitted (usually within 0.5 sec) to the main control at the Console. This is the key to maintaining accuracy in increasingly cluttered radio frequency air space.

The Beam Emitters and Track Sensors operate on invisible (to the unaided human eye) Infra-red light. The coded light frequencies are constantly received by the Track Sensors until a car interrupts reception ('breaks' the beam). Sensor trips are monitored by T-Link wireless modules and transmitted back to the main timer control at the console. Time accuracy is maintained at 0.001 seconds.

The IR Beam Emitter to Track Sensor transmission operates on Line-of-Sight principles. This makes alignment of the units critical. These units will operate over a wide range of conditions (full sun to total darkness) but should not be operated beyond the specification parameters (4 ft to 50 ft).

Once the system is properly set up and aligned on the racing surface, the timer console will 'monitor' the track sensors each time a run is made.

In racing mode, the system microprocessors take control of checking for a valid set of start conditions (expected blocked and unblocked sensors), then starts the lights (with adjustment for Full and Pro formats as well as any bracket or index adjustments) while watching for a start in either lane (a foul start will freeze the tree at the point of foul), records Reaction Time for each lane as the racers start. The system then watches for subsequent beam interruptions at the 60 foot, Half-track Speed and Finish points and Full-track Speed and Finish. After all data is collected, NHRA rules are applied to determine the winner and display this on the tree and console plus output to PCs, printers and Scoreboards connected to the system. Data includes RT, Redlights, ET, winner indication, Dial-in times, breakouts and total time.



Competition
12VDC Tree



Professional
110/230VAC Tree

2700 XL Wireless Quick Start Guide

This Quick Start guide can be helpful to use as a set of steps to follow for relatively experienced operators of the XL Wireless system.

- 1 Set up timing system hardware and cabling on race surface
- 2 Power on all T-Links and Infra-red Beam Emitter units
- 3 Connect all peripheral devices such as printers and scoreboards
- 4 Power on all printers and scoreboards; observe scoreboards for proper power up sequence.
- 5 Power on timing system at the Tree; observe light sequences for proper power up sequence.
- 6 Power on Console and any connected Wireless Link units
- 7 Go into Alignment Mode [*5#] and check alignment at all sensor locations. No counting digits means everything is aligned. Exit Alignment Mode [#] when done.
- 8 Go into System Config [*4] and the Configuration menu [*8] to set desired operating parameters
- 9 Select PRO or FULL starting lights [3]
- 10 If running brackets, enter Dial-in times [6]
- 11 If printing results, enter Car # [9]
- 12 Stage racers
- 13 Start race [0] or use the optional Starter's Button
- 14 Press [#] to return to main menu and clear last race
- 15 Next Race? Go to [9] or [12]

PACKAGE COMPONENTS**The standard Model 2700A XL Wireless dual lane drag package includes*:**

1 - 2700A Series Console Unit factory configured with the following features:

Dial-In Starts

Selectable Speed Trap of 10', 66' or 20M

Selectable Speed in MPH or KPH (Euro)

Standard or Custom Timeslip Header

Selectable Full/Pro Tree starting formats including Cross-talk

1 - 5802 wireless link at console ('Z' Unit)

1 - 02-2702 - Professional 110VAC Tree with Pre-stage**, Stage and Rear Facing Lights

1 - 3250 Wireless Tree Module ('A' Unit)

1 - 05-3251 Tree to Start Cable (35 ft)

2 - 5063L/R Dual Emitters (Pre-Stage/Stage)

2 - 5163L/R Dual Sensors (Pre-Stage/Stage)

1 - 6017B - Speed/Finish Option

2 - 5830 T-Link modules ('C'/'D' Units)

2 - 5042 IR Beam Emitters

4 - 5140 IR Track Sensors

2 - Cable Speed/Finish (06-5830)

2 - 5890 T-Link Battery Chargers

1 - Owner's Manual

With these parts, the system will provide Pre-Stage, Stage, Reaction Time (RT), Elapsed Time (ET), Speed and winner indication for two lanes.

Model 2700 Available Options

Tree Options:

02-2703 - Competition 12 VDC Tree w/Stage

02-2705 - Professional 230VAC Tree with Pre-stage**, Stage and Rear Facing Lights
7580Dx Flood lamp kit

Stage/Start Options:

6022A Single Beam Stage/Start

2 - 5058 IR Beam Emitter

2 - 5158 IR Track Sensor

6026A Dual Beam Staging - add Guard

2-Dual IR Beam Emitters (5054LM/RM)

2-Dual IR Track Sensors (5156LM/RM)

6023A Pre-Stage Electronics - add Pre-Stage and Guard beams

2-Tri-Beam Emitters (5067L/R)

2-Tri-Beam Sensors (5167L/R)

ET/Speed Options:

6017A 60 Ft ET

2 - 5040 Beam Emitters

2 - 5140 Sensors

1 - 05-3251 Tree to 60 Ft cable

6017CM Add Half-track ET

2 - 5830 T-Link modules ('E'/'F' Units)

2 - 5140 Sensors

1 - 5042 Beam Emitter

2 - Cable Speed/Finish (06-5830)

6017BM Add Half-track ET/Speed

4 - 5140 Sensors

2 - 5042 Beam Emitter

2 - Cable Speed/Finish (06-5830)

6512 AC Adapter for wireless

6502 AC Adapter for console

T-Link reconfigure kit

High Gain Antenna

Antenna Extension Kit

7540 Foam Stands

06-27SB Starter's Button - 100 foot cable

6038S Dot-Matrix Timeslip Printer Package

6038SW - Wireless Timeslip Printer Package

3128B XLscorePRO-W Race Management Software for PCs

6528C/6828C/6628C/6624C Single Line Dual Lane Digital Scoreboard

(5/8/15/24" digits respectively)

6810C/6610C/6410C Dual Line Dual Lane

Digital Scoreboard

(8/15/24" digits respectively)

4500 Data Communication PODs (for printers and displays greater than 100ft from console)

4520 Wireless RF Data Link

6085A Standard Duty Cable Winders

6070 Storage/Carry Cases

* Part numbers are for domestic US operation (900 mhz Wireless); a 'X' suffix part number designates non-USA shipments (2.4Ghz)

** Pre-stage operates via a console program button unless a Pre-Stage start option is available.

LOCAL REQUIREMENTS

Additional items required to operate the 2700 Series timing system package and options:

Batteries for Beam Emitters (see table pg 8)
AC TREE - 120VAC 20A circuit

AC TREE

1 -110VAC 20Amp circuit/230VAC 10Amp
1 - Surge Suppression Power Strip (20A)
8 - 60W 110/230VAC Stage/Pre-Stage Bulbs
20 - 100 W 110/230VAC Floodlights
(12 Yellow, 4 Green, 4 Red)
(bulb sets available from RaceAmerica)

Other options:

12VDC source for each printer or Scoreboard
(110/230 VAC with optional adapter)

PRODUCT SPECIFICATIONS

The following listing provides the designed performance specifications for the 2700 Series timing systems:

2700 XL Wireless

Start Lane Width	4 to 20 feet
Finish Lane Width	4 to 50 feet
ET Timer Capacity	up to 90.000 sec
RT Timer Capacity	up to 9.999 sec
Time Accuracy	0.001 seconds
Minimum Speed 10ft Trap	1.70 MPH
66ft Trap	11.25 MPH
AC TREE Dimensions	82" X 20" X 20"
AC TREE Weight	~ 55 pounds
DC TREE Dimensions	75" X 20" X 20"
DC TREE Weight	~ 45 pounds
Power Requirements:	
AC TREE	110 VAC - 20A
AC TREE	230 VAC - 10A
DC TREE	12VDC Source
Emitters	AA/C batteries

5830 T-Link

Frequency (domestic USA) 900MHz
(International) 2.4 GHz

Internal Battery	12VDC/5AH
T-Port Connections	
ID 'A'	Tree/Start/60 ft
ID 'C'	Lt Full-track Speed/Finish
ID 'D'	Rt Full-track Speed/Finish
ID 'E'	Lt Half-track Speed/Finish
ID 'F'	Rt Half-track Speed/Finish
ID 'Z'	2700 Console
Connection Type	RJ-45 Modular
Max Operating Range	-20°F to 120°F
Battery Life	24 hours

OPERATION

Track Sensors & Beam Emitter Operation

RaceAmerica utilizes a variety of Track Sensors and Beam Emitters in its timing systems. All operate on line-of-sight infra-red beam principles. The beam is created by the Beam Emitter and received by the Track Sensor. The operating specification is for a gap of between four and fifty feet between the Emitter and Sensor. These will operate in conditions ranging from full sun to total darkness without adjustment when properly aligned. The Beam Emitters require a power source (batteries or AC adapters) while the Track Sensors are powered from the cable to the T-Link or Tree. The infra-red beam is a coded frequency which is detected by the sensor. Different frequencies are used for different locations in different systems. Beam Emitter voltage should not fall below 4.5 Volts DC while operating.

The beam operates on a generally established condition (ie, the sensor senses the presence of the beam), and is interrupted (broken) by the racer (beam blocked). The beam will automatically re-establish after being blocked. The detection of vehicles passing through the beam rapidly highlights the sophistication of this technology. In fact, many small items such as leaves, water, snow can interrupt the beam. RaceAmerica minimizes the impact of these occurrences by requiring multiple short interruptions of the beam to indicate an interruption as well as verification of beam conditions before a race is allowed to start.

Beam Emitter and Track Sensor Options

Model 5040/5042 - IR Beam Emitter

Standard



5140D Sensor



5040B Emitter



5042B

Used for 60Ft, Speed and Finish track locations. Emitters utilize 4 'AA' batteries each; 5042 uses 'C' batteries

6022 Option



5158D Sensor

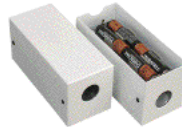

5058B Emitter

Start Line Sensors and Emitters are used for single beam Stage/Start. Emitters use 4 'AA' batteries each.

Standard

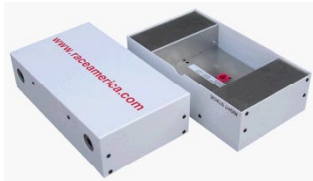

5163L/R Dual Beam Sensor



5063L/R Dual Beam Emitter

Pre-Stage and Stage Use 4 'C' Batteries for each emitter

6026 Option

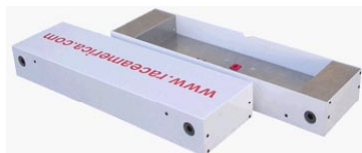

5156LM/RM Dual Beam Sensor



5054LM/RM Dual Beam Emitter

Professional Dual Beam Sensors and Emitters add Guard upgrade for ATV and Snowmobile applications. Use 4 'C' batteries for each emitter.

6023 Option



Model 5167L/R - Tri-Beam Sensor



Model 5067L/R - Tri-Beam Emitter

Professional Triple Beam Sensors and Emitters are an upgrade option used to add Pre-Staging and a Guard beam for all applications. Use 4 'C' batteries for each emitter.

Sensor and Emitter operation

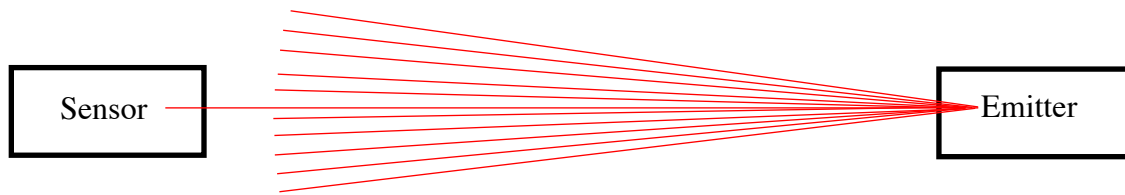

The Emitter throws a spot light like beam of infra-red light; the Sensor should be aligned near the center of the beam for optimal reception and alignment.

Dual-Beam Sensor (5163)

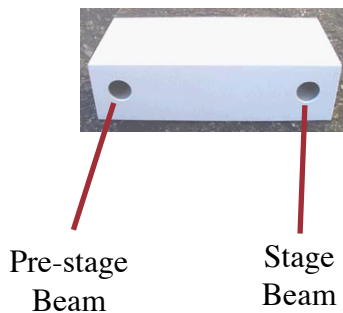

Tri-Beam Sensor (5167)

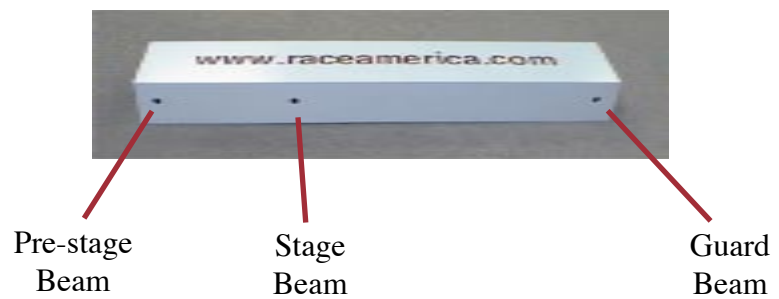

Fig 1 Sensor/Emitter Alignment

RaceAmerica Professional Dual-beam and Tri-beam Sensors utilize multiple infra-red frequencies due to the close proximity of each sensor to positively insure the correct signal is broken or blocked. This is why track position and orientation is critical.

RaceAmerica Single Beam Staging/Start Emitters/Sensors (5058/5158) operate in both blocked and unblocked modes depending on system conditions. The unblocked mode allows for alignment check. The mode is reversed once a car has staged (blocked the beam) and the system is about to start a race. The ET timer for a lane will start when the beam changes phase as the vehicle pulls away.

RaceAmerica offers several different sensor and emitter models (see Beam Emitter and Sensor models); depending on a variety of requirements. See the table of Sensor/Emitter combinations which operate with the Model 2700 XL Wireless system. In general, non-similar sensor/emitter pairs will

not function correctly. All start line sensor options connect to the same Start cable connections; make sure left and right lane positions are correct.

Wireless Operation

The wireless features of this system have greatly simplified set-up and tear down but must be followed carefully. Sensor alignment can be checked locally at each 5830 T-Link module as well as on the Console and mirrored to the Tree. The wireless T-Link transceivers operate best on line-of-sight principals; the Console unit is the main event coordinator. Keeping antennas up and off the ground as high as possible will optimize performance. The console can show the Radio Frequency (RF) Integrity on a relative basis between the various units. The system will operate correctly with low RF Integrity values however the system may have obvious delays while retries are accomplished during RF interference. Due to the nature of the technology,

no timing accuracy is lost. Antenna extension kits are available if necessary. All system components for racing (T-Link IDs 'A' thru 'F' plus 'Z') must be on the same Optimizer Code; peripheral devices such as scoreboards and printers may be on different codes. If other systems are operating in the vicinity (within several miles), they must be on different Optimizer Codes (see RaceAmerica for unique codes). **Do not operate any wireless device without the antenna on and do not operate wireless units within six feet of each other.**

The console keypad utilizes dual function keys. All functions shown in white function when pressed; functions shown in yellow require the * [SHIFT] key to be pressed two seconds before the desired function key is pressed.



The console also can display the battery charge level in each T-Link unit; charge batteries below 50% charge and before each event; charging may take 4 hours for each battery.

The 2700 XL Wireless system has numerous configurable options such as type of Tree (12VDC/110/230VAC) and Speed Trap which are saved after configuration in the console and tree. Operation of this wireless system is tolerant of many seemingly problematic situations. The technical design permits T-Link track units to be powered OFF/ON without missing more than one set of data; likewise with the Tree and Console and any peripheral devices. Generally, if a problem has occurred, end race **ENTER [#]** or the system reset **RESET [*0]** will automatically sync up all modules for operation and time accuracy to begin the next race.

SET-UP STEPS - 2700 SERIES

The content of this manual is designed to assist the new system owner with the RaceAmerica system, however, it is strongly suggested that the system be set up in a race simulation area to gain familiarity with basic operation of the components prior to race day. This can be done in a driveway or garage. Walking through beams can simulate vehicles for purposes of familiarizing oneself with basic operation.

STEP 1 - Familiarize yourself with the components pictured in this manual and how they interconnect. See the track layout diagrams for proper placement of each component. The T-Link units are location specific (see label on the bottom of each T-Link). Spare ID 'C' T-Links can be reconfigured for another position on the track (with the T-Link reconfigure kit). Ensure the correct sensor is connected at each position (with the matching emitter opposing it)

STEP 2 - Identify the emitter/sensor placement at the start line and finish line. The lane width should be set between four (4) and fifty (50) feet (optional 5050 Emitters have 75 ft range). Refer to the Track Sensors/Cabling Diagram page. Avoid running any of the system cables in conduit with 110/230VAC power lines as intermittent failures may occur. Speed Trap sensor spacing must match the system configuration to record accurate speeds. To help in determining initial beam emitter to track sensor alignment in wide track widths, eyeball a straight line between units. The system Alignment Mode will be utilized to verify alignment after power-up as well as using the T-Link units to view alignment locally.

STEP 3 - Assemble the Tree to the base as shown in the setup photos. Multiple base plates may be required for windy racing conditions. Install flood lamps on the AC Tree models.

STEP 4 - Place the electronic equipment in position as shown in diagram on page 14; connect the various cables. The tree should be about 30 feet out from the starting line.

STEP 5 - Connect cables for optional Starter's Button, Printer(s), PC(s), PODs, Wireless Links and Scoreboards to the appropriate connectors. The system will operate without these options connected. See Connecting Peripheral Devices for details about these options. Install antennas on all wireless link units including the back of the tree and console.

STEP 6 - Prepare to connect the system to the power source.

For the AC Tree option, connect the Tree to the AC power source. With AC power, a surge suppression power strip may be required at the Tree to compensate for line voltage fluctuations.

For the DC Tree, connect the RED (+ or Positive) and BLACK (- or Negative) alligator

clips to the 12VDC battery and you're ready to begin.

Operating the system from a battery connected to a charger or running car engine will result in an over voltage condition and damage the timer.

Go to Power-on/Self-test section to actually apply power to the various system components.

XL Wireless Console Connectors

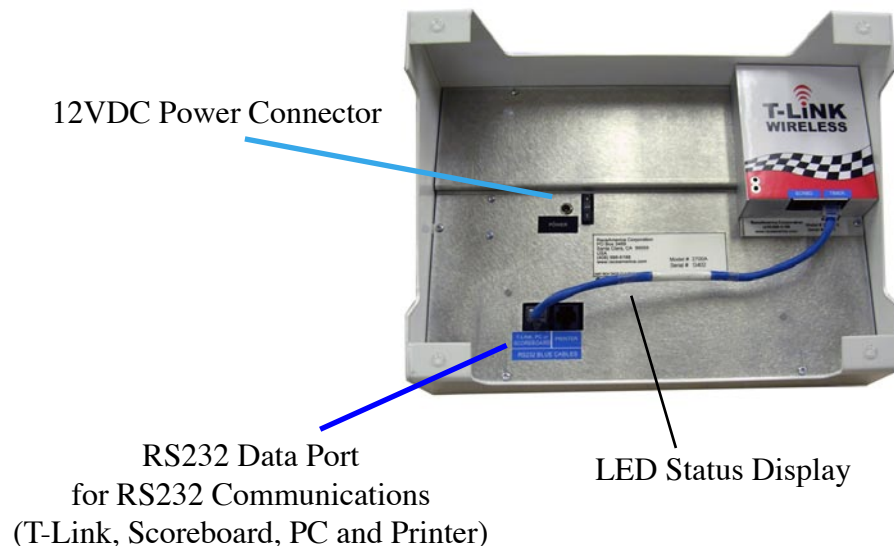

Fig 2 - Cable connectors on the underside of the XL Wireless console.



Assembled Tree and Base Plate

The assembled Tree - note the base orientation is at a 45 degree angle to the tree for increased stability.

Multiple base plates can be screwed together to increase stability if required for windy environments.

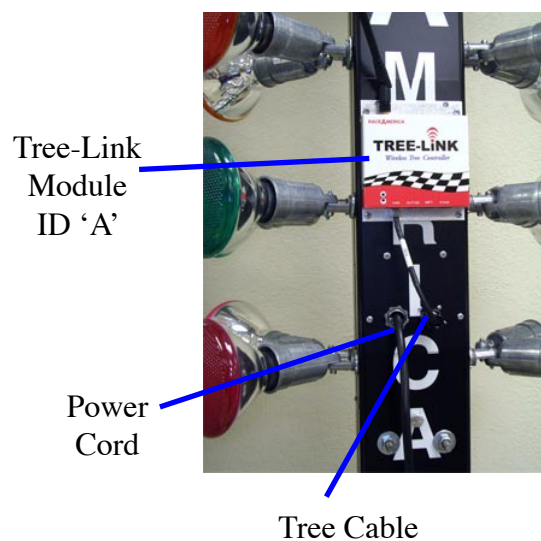

The Tree as seen from the back; do not connect the power until all cables have been connected and the system is ready for power up.

Fig 3 - Tree Assembly

TREE CLAMP ASSEMBLY



The iron pipe is held in place by two clamps at the base of the tree. Assembly is easy if the pipe is inserted into the base of the tree with the tree sitting face up horizontally. Push up the clamp from the bottom to allow the pipe to go through each of the two clamps; a Stop bolt is in place to limit the pipe travel.



The iron pipe clamps from the back side - the nuts should be tightened to a little more than finger tight to hold the tree adequately in the vertical orientation.

Lamps can be aimed at the drivers on both the 12VDC and 110/230VAC Trees. On the 12V Tree, the light pods adjust front to back by pushing them to the desired position and can be aimed up/down by loosening the screw on the side of the Tree, moving the pod and retightening the screw. The 110/230VAC Trees can be aimed by loosening the screws and moving the floodlamp to the desired position.

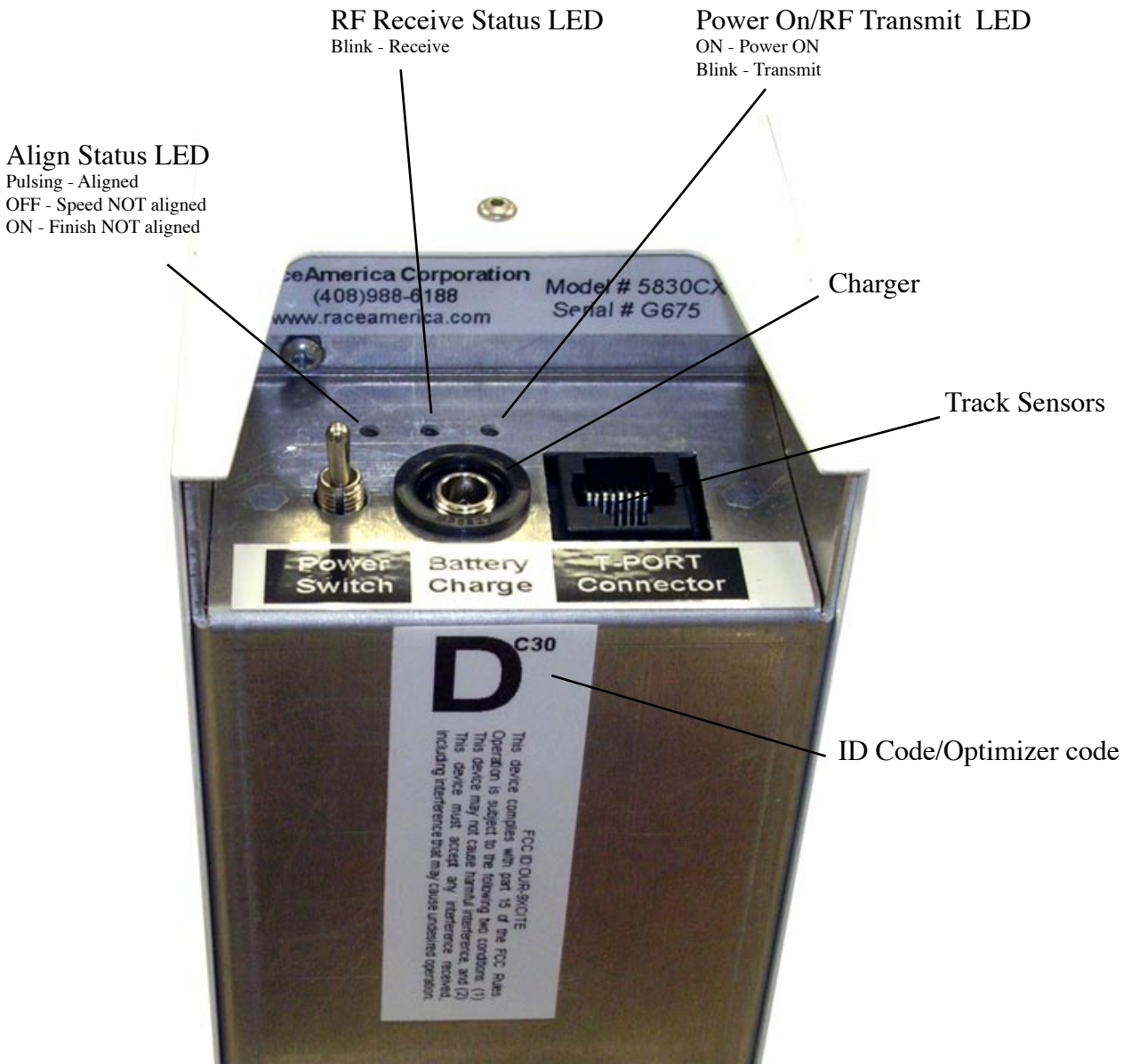

Figure 4 - 5830 T-Link control center. The track sensor cable plugs into the T-Port connector.

Care should be taken to plug in **ONLY** the battery charger in the Battery Charge connector.

T-Link bottom showing track position ID label.

‘D’ position is Right Lane Speed/Finish on optimizer code C30

Track sensor alignment can be monitored by observing the left LED.

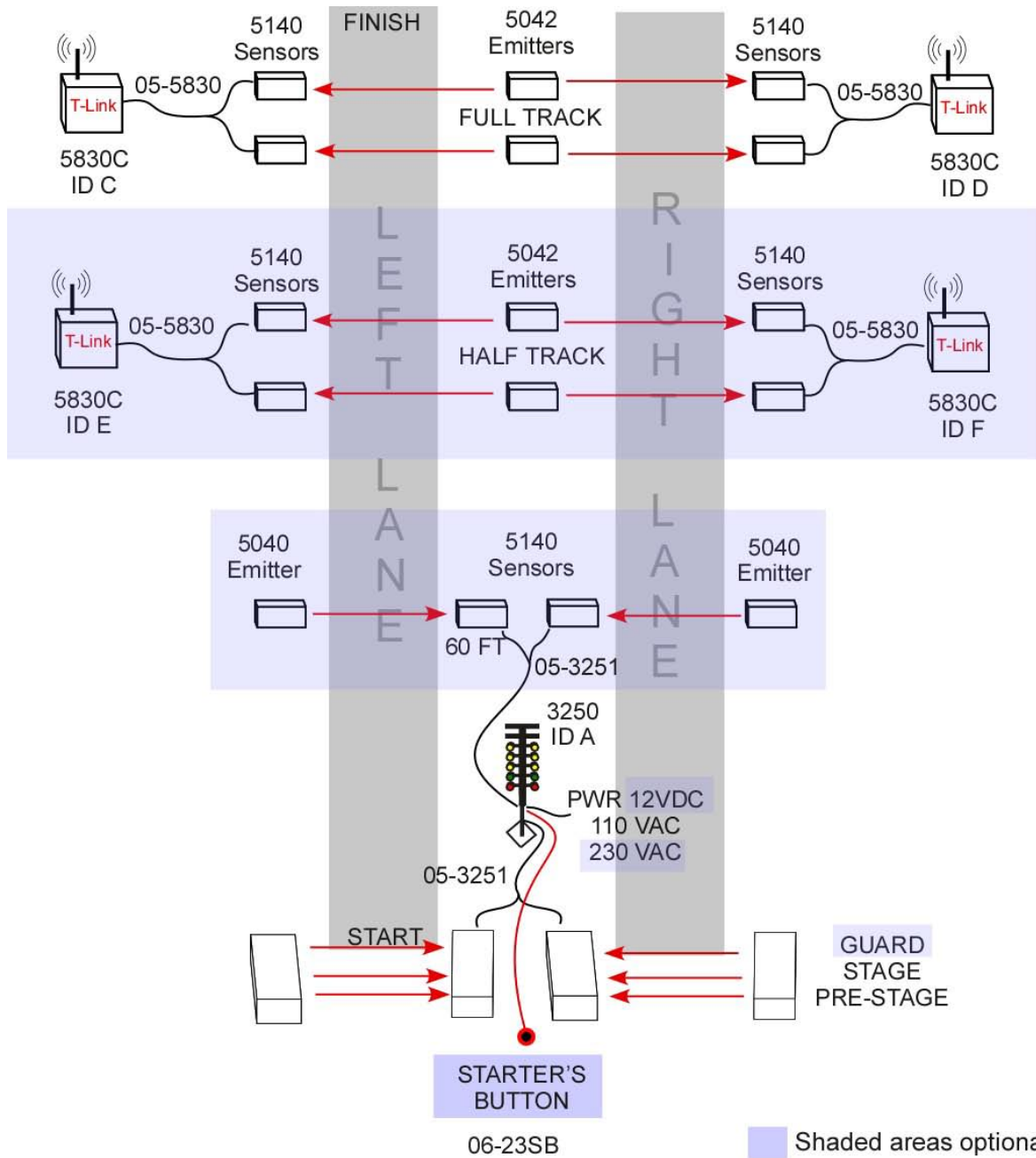

NOTES:

Speed Trap distance must be coordinated with the timer console in the CONFIG menu. Connectors for Speed Options are on the T-Link cable even if they are not purchased with the system.

Peripheral devices such as Printers, PCs and Scoreboards can operate up to 100 feet on RS232 communications; conversion to RS422 communications (with 4500 PODs) allows placement at greater distances. Communication to scoreboards is by a RS422 port on the console. Wireless RF Links are also available for all remote peripherals.

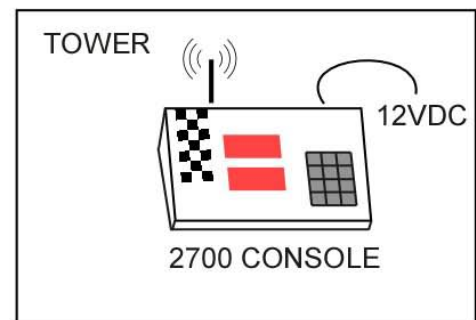

Fig 5 - Track Layout

KEYPAD FUNCTIONING

The console keypad utilizes dual function keys. All functions shown in white function when pressed; functions shown in yellow require the * [SHIFT] key to be pressed two seconds before the desired function key is pressed.

NAVIGATING TIMER MENUS

The XL Wireless Timer Console has a system diagnostic menu and two configuration menus:

The [*5 DIAG] Diagnostics menu includes Sensor Alignment, T-Link battery level and wireless RF signal integrity - functions used over the course of an event.

The [*4 SYSTEM] System menu includes Test sensors at start, Printer setup, Speed Trap configuration and Timeslip Print Header - functions rarely changed during an event.

The [*8 CONFIG] Configuration menu includes Starting Tree selection, Race results to display when available and Race finish point - settings likely to change each race or class.

The selections made in these menus are saved - even when power has been turned off. The system selections can be printed by pressing *1 [REPORT] on the keypad.

Each menu will be covered in detail in upcoming sections of this manual.



Fig 6 - Console Keypad

2700 rev A.01 Configuration Parameters

--- Tree Settings		
Pre-Stage Lights		On
Tree Input Power		110VAC
Redlights Allowed		First
Perfect RT=0.000		Off
Tree Win Light Pattern		4
--- Printer Settings		
Number of Line Feeds		10
Autoprint copies		1
--- Speed Trap Settings		
Trap Length		66 feet
MPH (USA) or Km/H(Euro)		MPH
--- Track Config Settings		
End of Race		Full
Total Elapsed Time		ET
Number of Lanes		Dual
--- Track Sensors		
Dial-ins	Display	Test
Reaction Time	Yes	
60 foot	No	Yes
Mid-Track Speed	No	No
Mid-Track ET	No	Yes
Full Track Speed	No	No
Full-Track ET	Yes	Yes

--- Timeslip Header
2700 Series XL Wireless
Drag Timing System

T-Link Wireless Technology

Fig 7 - Printout of Configuration Parameters
Press [*1] [REPORT]

DEFINITIONS OF THE TREE LIGHTS

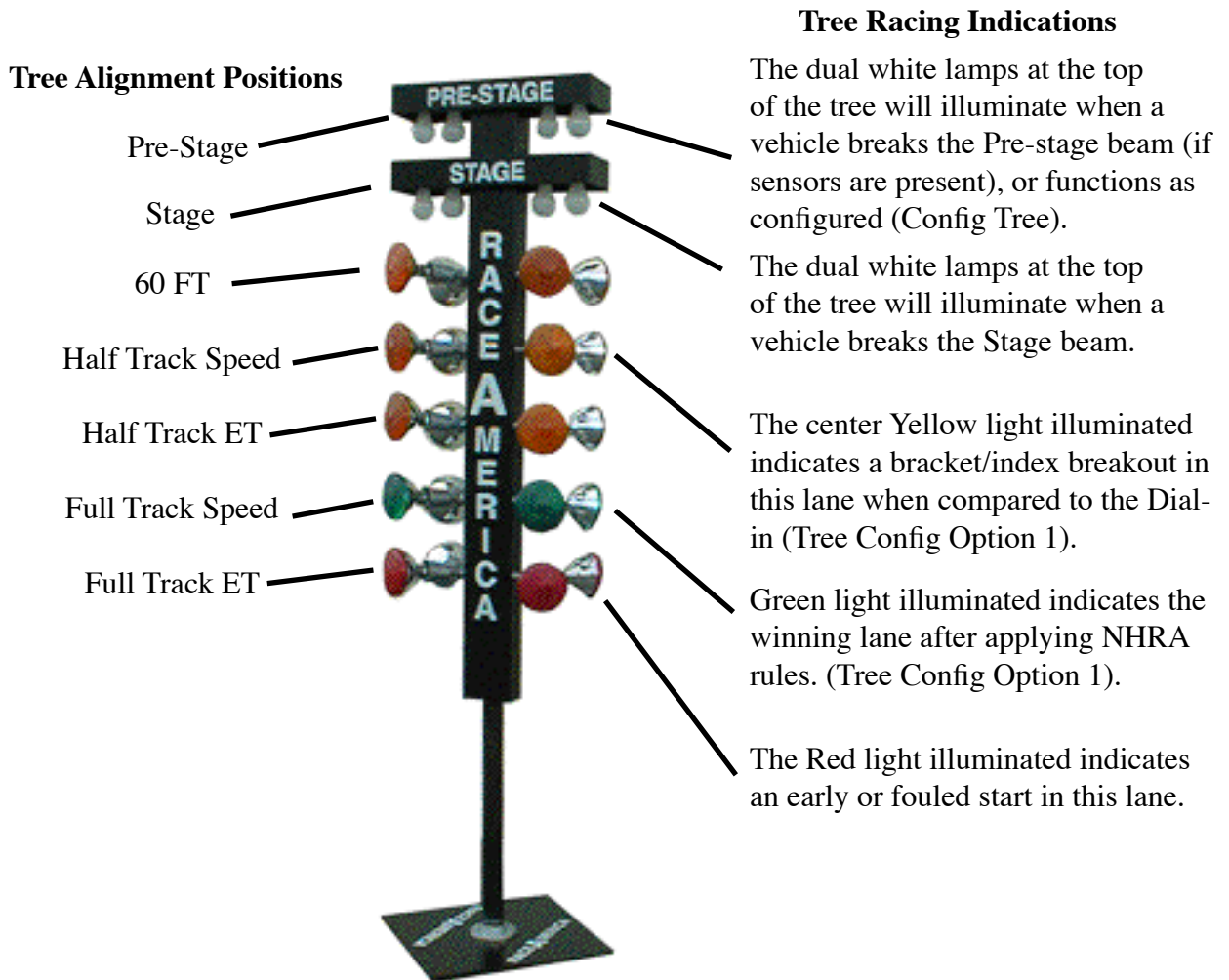

Fig 8 - The Tree displays sensor alignment by illuminating a bulb for each sensor position when in alignment mode (left legend)
The Tree also displays a full variety of information during racing activity (right legend).
Yellow, Green & Red lights have six winning lane options (*8#####).

POWER-ON/SELF-TEST

Power is applied to each independent component of the system. Verify that antennas have been installed on all T-Link units including the Tree-Link and console before applying power.

First, it is best to turn on the 5830 T-Links at Half-track and Full-track Speed/Finish and verify alignment on the T-Links (see page 13); secondly, power on the Tree and the Tree goes into a self-test of the microprocessor circuitry. This is an internal test as well as a visual check of the Tree lights. The Tree sequences through a lamp test

and circuitry test by illuminating the left red lamp and stepping up through the green and yellows, Stage and Pre-stage (Pre-Stage Tree only) on the left side, then on the right side to Stage and Pre-stage (Pre-Stage Tree). This repeats rapidly and then all lamps are flashed once to conclude the self-test. When the tree has completed the self-test display, the system is fully functional and ready for final configuration and setup. If the lights do not follow this sequence or some lights were not illuminated, check for insufficient power, defective bulbs or bad cable connections. At the end of this power-up, the tree goes blank; Pre-Stage and Stage lights are active and may be

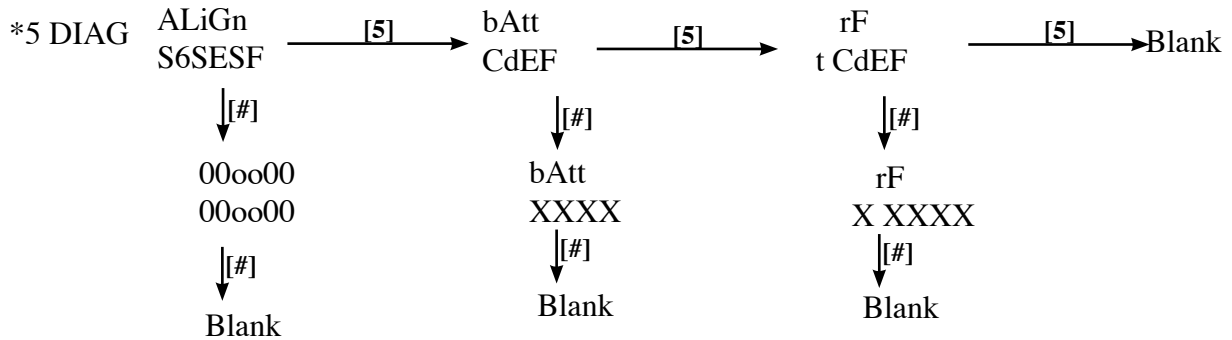

Fig 9 Diagnostic Menu, Press *5 [DIAG]

on until updated from the console. Third, connect the console to power; the console goes through a test and visual display of all segments in the display windows contained within the primary microprocessor. Normal communication is established with the Tree, the Tree lights will go out and the console will briefly show [uPdAtE] [trEE]. If communication is not established with the Tree; the display will briefly show [no] [trEE]. Press *0 [RESET] on the keypad to attempt to establish communications again if the tree is properly powered up also.

The test concludes when the upper console display shows the product model number [2700] and the lower display shows the code revision level [x.xx]. At the conclusion of the self-test, the Pre-Stage lights may be on until the system is reconfigured. Once the system has powered up, the Pre-Stage (if present and properly configured) and Stage sensors are active and indicate a vehicle present when blocked or misaligned.

If a printer is connected to the Console, press [*1] REPORT to print a summary of currently saved parameters. See Fig 7 for an example. Use this summary to determine what needs to be changed, if anything.

If scoreboards are connected, press **2 to send sample data to the scoreboards for display. It should show left lane with 12.345/135.79 ET/Spd and the right lane with 67.890/246.80 ET/Spd.

At the conclusion of the console power-up sequence, the system can be Configured (*8), Diagnosed (*5), operated (0) or put into background monitoring (#) mode.

BACKGROUND MONITORING

Background sensor monitoring gives the race director early warning about a possible problem and occurs when no other functions are being performed such as configure, print, enter dial-in or run a race. The background monitoring mode will display [SEnSor] [-tESt-] in the upper/lower windows if all sensors are aligned. If any sensors selected for test (*4) plus Finish are out of alignment, the display will show the offending positions in the following format - [16SESF] [r6SESF] - where the upper/lower windows are left/right lanes respectively and the positions 60ft, Half-track speed, Half-track ET, Full track speed and Full track ET. Properly aligned sensors will show with a (-), misaligned sensors will show the position letter [l----F] [r-----] and wireless units not connected (possibly no communications/no T-Link) will show three horizontal bars.

Background monitoring will automatically switch between [SEnSor] [-tESt-] and [l----F] [r-----] as alignment conditions change. Background monitoring checks the sensors and updates the displays every five seconds. Use Alignment mode for continuous alignment setup and testing. Use background monitoring as a guide for starting races; a sensor out of alignment will not stop a race but may indicate a bad time or speed if ignored.

SINGLE or DUAL LANE OPERATION

The 2700 can operate in single or dual lane mode. This is configured in the 'Configuration' menu (*8888###). When in single lane mode (right lane), Pre-Stage/Stage lights for both lanes are controlled by the right lane, a single lane timeslip (Fig 12B) replaces the dual lane timeslip and only selected right lane sensors are monitored between runs.

Note: One lane in a dual lane setup can be operated without reconfiguring for single lane operation.

DIAGNOSTICS MENU (Fig 9)

SENSOR ALIGNMENT

All RaceAmerica timing systems have an alignment mode. This is very useful for verifying correct Emitter/Sensor alignment. Wireless systems have alignment checks at each T-Link which continuously displays alignment status with the left LED as well as live on the console and mirrored on the Tree. After the track layout has been determined and the Sensors and Emitters placed in the proper positions, enter alignment mode section within the Diagnostics menu on the console by pressing the [***5#**] **DIAG ALIGN ENTER** keys to verify correct alignment. Alignment conditions also display on the Tree as shown in the definitions of Tree Lights picture. The LED Display momentarily indicates the position of each sensor on the console display with letters representing each emitter/sensor pair [**S6SESF**]. The digits indicate Stage, 60 foot, Half-track Speed, Half-track ET, full-track Speed and Full-track Finish respectively. Left lane sensors are monitored in the top display and Right lane sensors in the lower display. The Status Display then changes each digit to a zero for each sensor being monitored [**000000**]. If the Beam Emitter and Track Sensor are operating properly and aligned, the '0' digit will not change and the Tree lights will be OFF. If the Beam Emitter and Track Sensor are not properly aligned, the '0' digit for each emitter/sensor pair will count slowly if slightly out of alignment or continuously if they

are not functioning properly, way out of alignment or not present (a triple bar [=] is displayed) and the corresponding Tree light will be on or flickering. Once the emitter/sensor pair are aligned properly, the digit will stop counting and the Tree light will go out. If the alignment is off a little or intermittent, the digit for that emitter/sensor pair will count when they float out of alignment. Note that the Pre-Stage position is always active on the Tree. It should also be noted that once the zero digit has started counting, it will never stop at zero again unless Alignment Mode is exited and re-entered. This can be helpful for leaving the system in alignment mode for an extended period of time to check on an intermittent condition.

To maximize the alignment of the emitter/sensor pairs, it is suggested to rotate the beam emitter slowly left and right until the alignment for that pair begins to count. This technique will determine the maximum lateral detection angle. Rotating the beam emitter up and down until the alignment starts counting determines the maximum vertical detection angle. Once these extremes are established, position the Beam Emitter in the center of the left/right detection angle and up/down detection angle. Repeat this same process with the other beam emitters and track sensors. This will maximize the alignment accuracy.

Remember, the beam emitters and track sensors operate on a 'Line-of-Sight' concept and may require shims if they are installed on a race track with a crown. Leaves, people, and other debris will also break the beams and could give false signals, so keep everyone and everything clear of the beam emitters and track sensors during racing activity. Lane width should be between four and fifty feet; eyeball a straight line between the two to get close.

Press the [**#**] **ENTER** key to exit Alignment Mode and return to Background Monitoring mode.

If optional Dual-Beam (Stage with Guard beam) or Tri-Beam Start Line Track Electronics were purchased to add the True Guard Beam and Pre-stage beams to the Stage at the starting line, follow this alignment technique to properly align all beams.

If optional Guard beams are present, 18

*4 SYSTEM

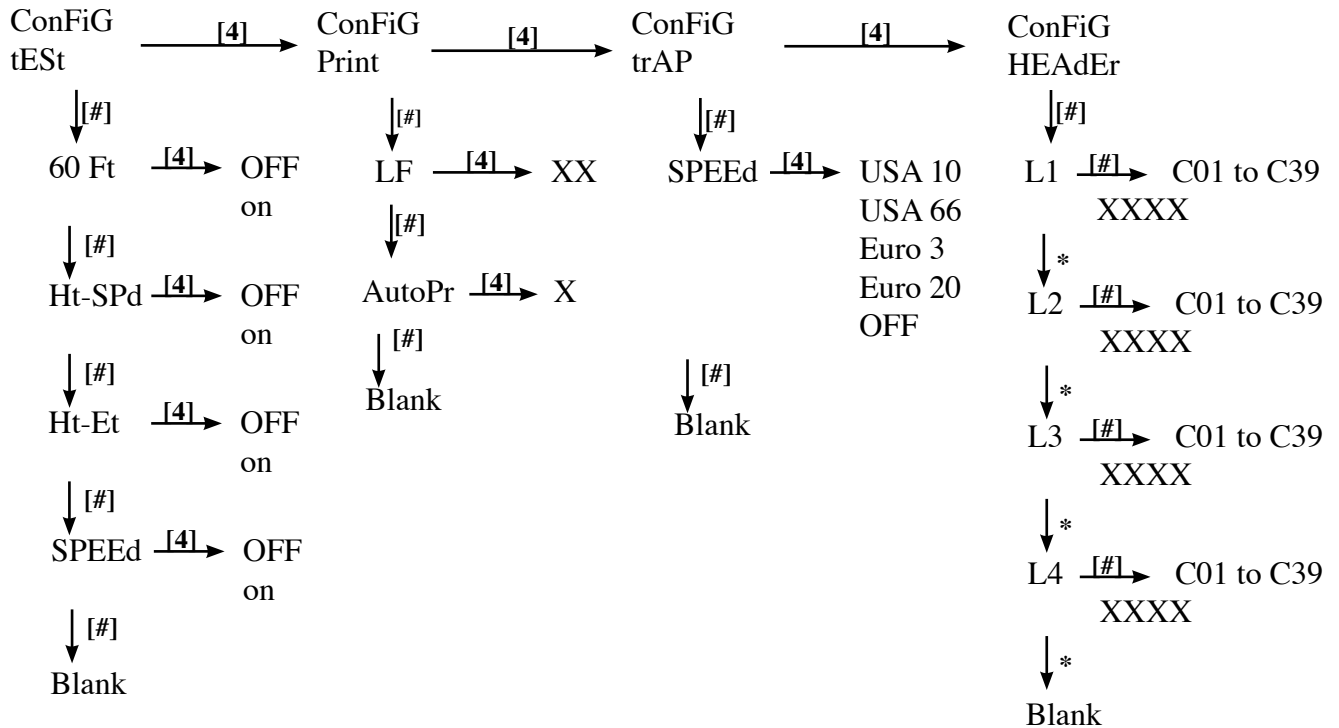

Fig 10 System Settings Menu, Press *4 [SYSTEM]

position the Dual/Tri-Beam Emitters and Sensors on the track and connect the start line cables as outlined in the timing system hardware manual. Power on the timing system and enter into alignment mode. Align the Pre-stage beams as usual and confirm Pre-stage beam alignment and operation. Next block the Stage beam on either the Dual/Tri-Beam Emitter or Sensor. With the Stage beam blocked, the Stage light on the tree will illuminate when the Guard beam is properly aligned. Rotating the Dual/Tri-Beam Sensor left or right on the track will cause the Guard beam to go out of alignment and the Stage light on the tree to go out. Position the Dual/Tri-Beam Sensor so the Pre-stage beam and the Guard beam are fully functional. This can be tested by blocking and unblocking the Pre-stage (if present) and Guard beams. Unblock the Stage beam and the Stage light on the tree will go out. If the Stage beam does not go out, fine tune the positioning by slowly rotating the Tri-Beam left or right until the Stage light goes out. Recheck the Pre-stage and Guard beams for alignment.

To final check all three beams are properly aligned, block the Pre-stage beam and the Pre-stage light on the tree will illuminate. Block the Stage beam and the Stage light on the tree will illuminate. With the Stage beam blocked, block the Guard beam also and the Stage light on the tree should go out.

If all three beams are not aligned, check the parallel position of the Dual/Tri-Beam Emitter then repeat the Dual/Tri-Beam Sensor alignment process on the above rotating the Dual/Tri-Beams in smaller increments left or right.

NOTE: When beam emitters are powered on, a pink glow can be observed when looking into the emitter from close range; toggle the switch to observe the change (Use caution and look for only brief periods to avoid visual problems). Sensors get power for an internal red LED when connected to the cable. Checking for this light can confirm power is getting to each sensor.

BATTERY LEVEL

The T-Link battery charge level can be viewed by pressing ***55# [Shift Diag] [ConFiG] [bAtt] [CdEF]** keys. The letters represent T-Link IDs. 'C' sensors (Full-track Left Lane Speed/Finish), 'D' sensors (Full-track Right lane Speed/Finish), 'E' sensors (Half-track Left Lane Speed/ET) and 'F' sensors (half-track Right Lane Speed/ET). The letters will be replaced by the percentage of battery power remaining. 0 for 0%, 1 for 10%, 2 for 20%, etc and a dash for 100%. Any reading above 40% should be adequate for hours of operation.

Press **# [ENTER]** to return to Background Monitoring mode.

RF INTEGRITY

The T-Link RF signal integrity can be viewed by pressing ***555# [Shift Diag] [ConFiG] [rF] [t CdEF]** keys. The display will show **[-rF- [x xxxx]**. The x's represent T-Link IDs. 't' (Tree), 'C' sensors (Full-track Left Lane Speed/Finish), 'D' sensors (Full-track Right lane Speed/Finish), 'E' sensors (Half-track Left Lane Speed/ET) and 'F' sensors (Half-track Right Lane Speed/ET). The dashes on the display will begin to count up as signals are received from the T-Link units on the track. 0 displayed represents 0%, 1 represents 10%, 2 represents 20% etc. until a dash appears representing 100%. This is an indication of the consistency of the RF integrity. If this number jumps around, there is a high level of interference in the area. If the number remains high, the RF signal strength is very good. If the number remains low, the RF integrity is somewhat weak. The position of the T-Links and their antennas can be moved to optimize the RF Integrity level.

Press **# [ENTER]** to return to background monitoring.

SYSTEM MENU (Fig 10)

CONFIGURE SENSOR TEST

Select the sensors to be tested after a start request is sent to the tree and before the tree comes down; the Finish sensors are always checked. Press ***4 [Shift System] [ConFiG] [tEst]**. Press **# [ENTER]** to view the current selection for 60 ft sensors **[60 Ft] [on]**; press **[4]** to toggle to the opposite selection; press **[#] ENTER** to accept a choice and move to Half-track Speed **[Ht-SPd] [OFF]**; press **[4]** to toggle to the opposite selection; press **[#]** to accept a selection and move to Half-track ET **[Ht-Et] [on]**; press **[4]** to toggle to the opposite selection; press **[#]** to accept a selection and move to Full-track Speed **[SPEED] [OFF]**; press **[4]** to toggle to the opposite selection; press **[#]** to accept choice and return to background monitoring.

CONFIGURE TIMESLIP PRINTER

The number of timeslips to automatically print and the number or line feeds to eject a timeslip to tear it off.

Press ***44 [Shift System] [ConFiG] [Print]**. Press **# [ENTER]** to view the current selection for Printer Line feeds **[LF] [10]**; enter a new number using the keypad; press **[#] ENTER** to accept the number; next **[AutoPr] [1]** will show indicating the number of timeslips to autoprnt (blinking digit); press a number on the keypad (0-9) for the desired number of copies; press **[#] ENTER** to save and return to background monitoring.

CONFIGURE SPEED TRAP

Using wireless T-Link units, the cable supplied is long enough to set up any of the following speed trap lengths.

Press ***444 [Shift System] [ConFiG] [trAP]**. Press **# [ENTER]** to view the current selection for Speed Trap, cycle through **[trAP] [USA10]** for 10ft MPH trap, **[trAP] [USA66]** for 66ft MPH trap, **[trAP] [Euro3]** for 3 meter Km/PH trap, **[trAP] [Euro20]** for 20 meter Km/PH trap and

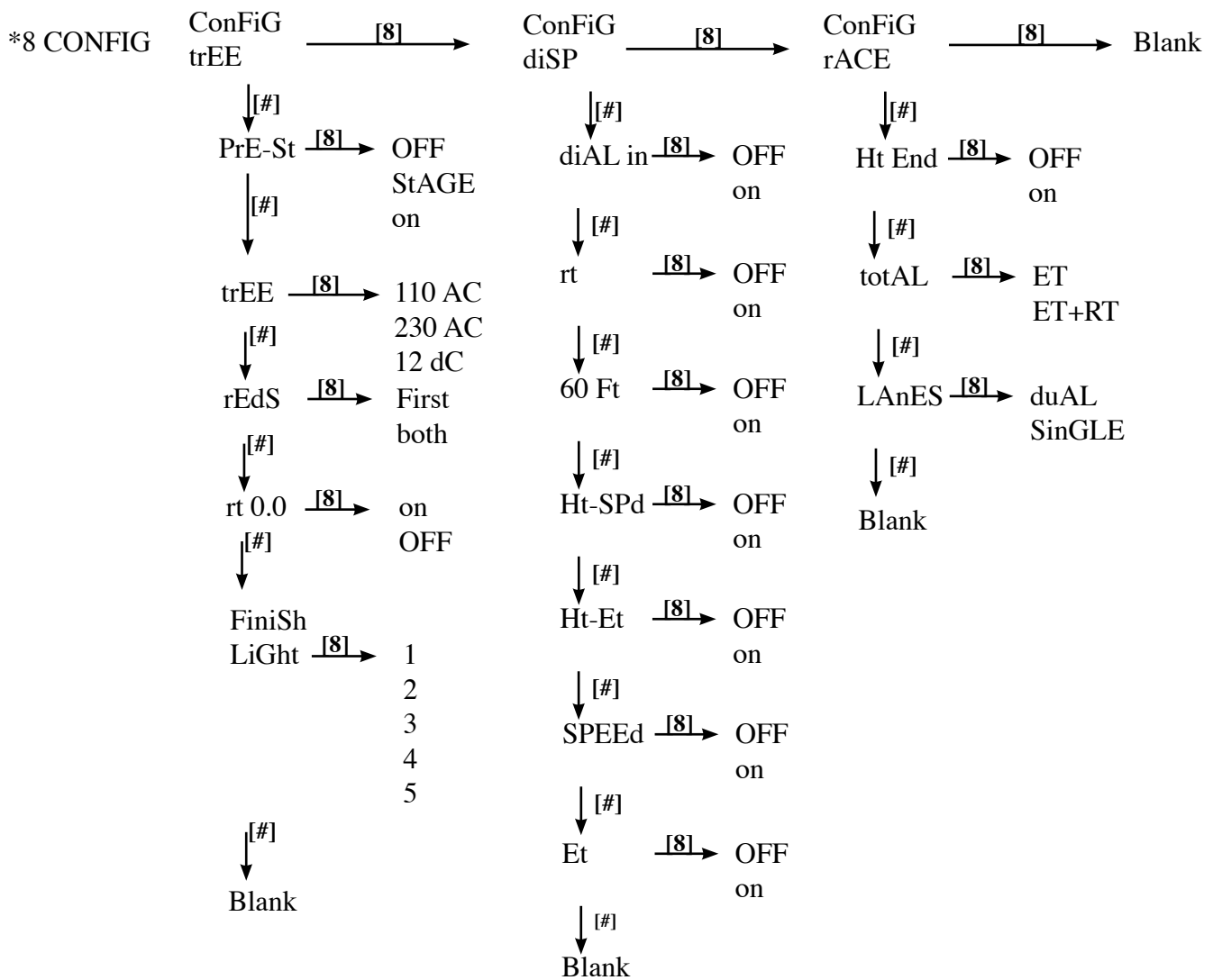

Fig 11 - Configuration Menu, Press *8 [CONFIG]

[trAP] [OFF] by repeatedly pressing [4], press [#] [ENTER] to accept the selection and return to background monitoring.

CONFIGURE PRINT HEADER

The XL Wireless allows a custom four line timeslip print header of up to 39 characters per line. Input is accomplished using character codes for each desired character position (see worksheets). Press *4444 [Shift System] [ConFiG] [HEAdEr]. Press # [ENTER] to view the setup dialog as follows [L1 C01] [XX00] indicating Line 1 Character 01; the XX is prompting for the character code for the desired character; refer to the

worksheet for the correct code, press [#] to move to character 02 [L1 C02] [YYXX00] where YY is Character 01 and XX is prompting for character 02; continue for up to all 39 characters in the line. Press [*] to move to Line 2 [L2 C01] [XX00] and continue for all four lines. When done with all four lines, press [*] to return to background monitoring.

CONFIGURE MENU (Fig 11)

CONFIGURE TREE

Use the Configure menu to select Tree functions, results to be displayed, how they are

calculated and single or dual lane operation. Press ***8 [Shift ConFiG], [ConFiG] [tree]**. Press **# [ENTER]** to view the current selection for use of Pre-Stage lights **[PrE-St] [on]** which means Pre-Stage is ON and will function with the track electronics option; repeated presses of the **[8] CONFIG** key cycles the lower display through the other options. These include **[OFF]** which deactivates all Pre-Stage display, **[StAGE]** will turn on the Pre-Stage lights with the Stage lights, **[On]** will set Pre-stage to operate independently. Press the **[#] ENTER** key to accept the desired condition and move to power source **[trEE] [110 AC]**; press **[8]** to view **[trEE] [230 AC]**; press **[8]** to view **[trEE] [12 dC]**; press **[#]** to select the correct tree voltage and move to red lights to be displayed **[rEdS] [FirSt]** to display only the first lane to redlight. If both lanes redlight, press **[8]** to cycle to **[rEdS] [both]**. Press **[#]** to move to Reaction Time (RT) reporting **[rt 0.0] [Off]**. Select OFF to use the 0.400/0.500 reporting from the last yellow or select **[On]** to report RT from the Green light (positive or negative); press **[#]** to select the winning lane lights to display **[FiniSh] [LiGhtX]** where five choices for **X** (1-5) can be selected. Choice '1' displays winning lane, redlights and breakouts; choices '2-5' have animated winning lane displays only (go ahead, check 'em out); press **[#]** to go to background monitoring.

CONFIGURE DISPLAY

Use the Configure menu to select which results are displayed before, during and after a race. Results displayed on the console will also be sent to all scoreboards. Press ***88 [Shift ConFiG], [ConFiG] [diSP]**. Press **# [ENTER]** to view the current selection for Dial-ins **[diAL in] [on]**; press **[8]** to toggle to the **[diAL in] [Off]** which will not display dialins on the scoreboard. Press **# [ENTER]** to view the current selection for Reaction Time **[rT] [on]**; press **[8]** to toggle to not display RT. Press **# [ENTER]** to view the current selection for 60 ft sensors **[60 Ft] [on]**; press **[8]** to toggle to not display 60 ft times. Press **[#] ENTER** to accept a choice and move

to Half-track Speed **[Ht-SPd] [OFF]**; press **[8]** to toggle to not display Half-track Speed. Press **[#]** to accept a selection and move to Half-track ET **[Ht-Et] [on]**; press **[8]** to toggle to not display Half-track ET. Press **[#]** to accept a selection and move to Full-track Speed **[SPEEd] [OFF]**; press **[8]** to toggle to display Full-track Speed. Press **# [ENTER]** to view the current selection for Elapsed Time **[Et] [on]**; press **[8]** to toggle to not display Full-track ET. Press **[#]** to accept choice and return to background monitoring.

CONFIGURE RACE

Use the Configure menu to select finish location (full-track or half-track) and how times are calculated (ET or ET+RT). Press ***888 [Shift ConFiG], [ConFiG] [rACE]**. Press **# [ENTER]** to view the current selection for ending the race at Half-track **[Ht End] [OFF]**; press **[8]** to toggle to Full-track end of race; press **# [ENTER]** to view the current selection for total ET time reporting **[totAL] [ET]**; press **[8]** to toggle to **[Et rt]**; press **# [ENTER]** to view the current selection for one or two lane racing **[LAnES] [duAL]**; press **[8]** to toggle to **[SinGLE]**; press **# [ENTER]** make desired selection and return to background monitoring.

At this point the timer is ready to time the first run. It might be a good idea to recheck the sensor alignments after changing any configurations.

RUNNING A RACE

The system is now powered on, aligned and configured. Press the **[#] ENTER** key to clear any display condition and show background monitoring.

Next, race parameters for starting light sequence (Pro or Full), Dial-in times and Car numbers can be entered if time slips are to be printed or data capture software will be collecting race results. Select the desired starting sequence (Pro or Full) by pressing the **[3] TREE** key; the current Dial-in/Crosstalk and Tree will show as **[di Ct] [Full .5]**. 'di' indicates a non-zero Dial-in is currently entered (**[6]** key); 'Ct' means Crosstalk

is active (by definition, Crosstalk only affects Full tree starts). Press **[3]** repeatedly to cycle through the other Tree options - **Pro .4, Full .4, Pro .5** - selecting the desired light by pressing **[#] ENTER**. After a selection, the display will show the current Crosstalk setting **[Ct] [OFF]**; press **[3]** to toggle to turn Crosstalk on; press **[#] ENTER** to close out Tree selections and display background monitoring

The PRO format turns on all yellows then green at a 0.400 or 0.500 second interval. The FULL or SPORTSMAN format turns on each yellow, then green at 0.500 or 0.400 second interval.

The Crosstalk option is similar to the NHRA Crosstalk function and is enabled for bracket racing under a FULL starting tree. When the slower vehicle's top yellow light illuminates on

the tree, the top yellow in the other lane will also illuminate. The slower lane's yellows will illuminate in sequence as usual while the other lane's top yellow will remain illuminated until that lane's bracket advances to the next yellow. When Crosstalk is OFF, the tree starting sequence is not altered from normal starting sequences.

Each stored race configuration remains the starting settings until changed (Car #, Dial-in, starting tree) or power is cycled off.

If running brackets, press the **[6] DIALIN** key to view the current Dial-in times; press the **[6]** key again to zero out the existing times and enter new numbers (top display is for left lane and bottom display is for right lane times); input the racers Dial-in times. Press the **[#] ENTER** key to accept the new times (all zeros will be heads-up format). Bracket racing is a form of

2700 Series XL Wireless Drag Timing System			
T-Link Wireless Technology			
Left	by 1.256		Right
1234	Car Number	WIN	9876
9.301	Elapsed Time		8.303
82.45	Vehicle Speed		92.63
0.955	Reaction Time		0.697
NO	Redlight		NO
0.000	Dial-in/Index		0.000
NO	Breakout		NO
2.813	60 Ft Time		2.931
55.32	Half Track Speed		59.64
6.183	Half Track ET		6.108
Timing by RaceAmerica's T-Link Wireless www.raceamerica.com			

Fig 12A - Dual lane timeslip example

2700 Series XL Wireless Drag Timing System	
T-Link Wireless Technology	
Car Number	4321
Elapsed Time	7.903
Vehicle Speed	105.23
Reaction Time	0.527
Redlight	NO
Dial-in/Index	0.000
Breakout	NO
60 Ft Time	2.742
Half Track Speed	70.24
Half Track ET	5.408
Timing by RaceAmerica's T-Link Wireless www.raceamerica.com	

Fig 12B - Single lane timeslip example

handicapping where the expected Elapsed Time is entered for each racer, the starts are adjusted so both racers with perfect reaction times and both run their Dial-in, they will finish at the same time. If either racer runs faster than their Dial-in time, they 'Breakout' and this will be displayed after the race by illuminating the middle yellow light on the Tree if Finish Light sequence [1] was selected; it will also print on the timeslip.

Press the [9] **CAR #** key to view the current Car numbers; press the [9] key again to zero out the existing times and enter new numbers (top display is for left lane and bottom display is for right lane times) input the racers Car numbers. Press the [#] **ENTER** key to accept the new numbers (all zeros is acceptable). This information will appear on timeslips and in data captured in PCs after the race.

Stage the race vehicles by moving them into the Pre-Stage (if present) and Stage beams (Pre-Stage and Stage lights on the Tree come on).

To start the race, press the [0] **RUN** key. The Tree will begin the starting light sequence. If a driver interrupts the starting beam prior to the green lamp illuminating in that lane, the starting sequence will stop for that lane, freezing the tree and illuminating the red/yellow lamps indicating a redlight start in that lane. Once a driver crosses the starting line, they must cross the finish line to complete their run. As the race progresses, the displays (and connected scoreboards) will display selected intermediate data ([*88] **[CONFIG] [DISP]**) as it becomes available. The Tree will continue to illuminate the red or green lamps until both lanes have crossed the finish line (or only one lane crosses the finish line in the case of a BYE run). When both vehicles cross the finish line, the Display will indicate the Elapsed Times (ET or ET+RT if selected).

After both lanes have completed their runs, the Tree will display the redlight conditions of each lane if Finish Light sequence [1] was selected. The selected Finish Light sequence will be illuminated for the winning lane after applying NHRA rules for reaction time, breakouts, redlights, and first to cross the finish line. If a printer option is present, the selected number of timeslips will print. **[Print] [SLiP]** will display in window after a race when

printing is occurring. Additional prints can be made by pressing the [*7] **PRINT** key. If a Scoreboard option is present, the Scoreboard will display the selected information (ET/SPEED).

The Console Display will show the **Left ET** in the upper display and the **Right ET** in the lower display; a box [o] to the left of one ET indicates the winning lane. After each race, the race data can be displayed: Press [1] to view Reaction Times, press [2] to view 60 ft times; press [7] to view Speed, if Half-track ET is connected, press [5], press [4] to view Half-track Speed.

Race results are available for recall and reprint until the [0] key is pressed for a new race.

Dial-in racing is started by pressing the [6] **DIALIN** key on the Keypad to display current Dial-ins, then press [6] again to enter the Dial-in for the Left and Right lanes; the next start will apply the appropriate differential to the starting sequence of the race. At the end of a Dial-in race, the Tree will additionally indicate a bracket breakout if one occurs on either lane by illuminating the center yellow light if Finish Light sequence [1] was selected. Dial-in selections can be checked by pressing the [6] key.

NOTE: As a general rule, if the Tree has a green or red lamp illuminated, one of the lanes has not completed its run and crossed the finish line. The [#] **ENTER** key must be pressed by the operator to end the race and capture the data up to the point of the problem.

TIME & COUNT FUNCTIONS

The console and network scoreboards have a provision to set a twelve hour clock and display time on connected scoreboards. Additionally, a 60 minute countdown timer can be used to time breaks in the race action.

To set the time of day, press [*6] **TIME** and enter a valid time of day; press [#] **ENTER** to send the time to the scoreboards. Press [#] **ENTER** again to clear the display and scoreboards. Press [*6] to view time on the console. To start the countdown clock, press [*9] **COUNT** and enter a beginning countdown point (e.g. 2000 for 20 minutes), press [#] **ENTER** to send the countdown

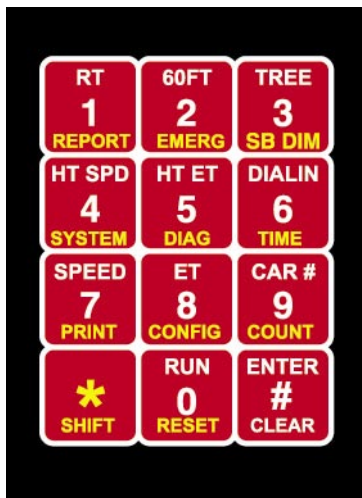

Fig 13 - Model 2700 Keypad

status to the display and scoreboards; press [#] **ENTER** again to clear the countdown. Press [*9] to view time remaining on the console.

KEYPAD FUNCTIONS

The Model 2700 Drag System utilizes a second function keypad; functions printed in white operate when pressed; functions printed in yellow require the 'SHIFT' button to be pressed two seconds before the desired second function yellow key is pressed.

The following defines the keypad key functionality:

KEY 0

The [0] **RUN** key is used to start a race.

KEY 1

To display the RT results from the last run, press the [1] **RT** key to view Reaction Times for both lanes; press [#] to clear.

KEY 2

To display the 60 ft ET results from the last run, press the [2] **60FT** key to view 60 ft ETs for both lanes; press [#] to clear.

KEY 3

Press the [3] **TREE** key to view the currently selected starting tree; press [#] **ENTER** to accept. Repeated presses of the [3] **TREE** key cycles through the available starting light sequences:

PRO 400	(standard)
FULL 400	(optional)
PRO 500	(optional)
FULL 500	(standard)

A PRO Tree illuminates all yellows, then Green at the selected interval; a FULL Tree (also known as SPORTSMAN Tree) illuminates each yellow, then green at the selected intervals.

KEY 4

To display the HALF TRACK SPEED results from the last run, press the [4] **HT SPD** key to display Half Track Speed results for both lanes; press [#] **ENTER** to clear.

KEY 5

To display the HALF TRACK ET results from the last run, press the [5] **HT ET** key to display Half Track Speed results for both lanes; press [#] **ENTER** to clear.

KEY 6

The [6] **DIALIN** key is used to recall and enter the bracket or index for each lane. Press the [6] key to view the current Dial-Ins; press the [6] key again to change the times. Press the [#] **ENTER** key to accept the changes.

KEY 7

To display the FULL TRACK SPEED results from the last run, press the [7] **SPD** key to display speed for both lanes; press [#] to clear.

KEY 8

To display the ET results from the last run, press the [8] **ET** key to view Elapsed Times for both lanes; press [#] to clear.

KEY 9

The **[9] CAR#** key is used to enter the Car number for each lane. Press the **[9]** key to view the current Car numbers; press the **[9]** key again to change the times. Press the **[#] ENTER** key to accept the changes.

KEY*

The **[*]** key is used as a 'SHIFT' key to enter the second key function modes (Yellow type).

KEY #

The **[#] ENTER** key is used to accept input values, end races without a finish or clear the Tree, and return to background monitoring.

KEY *0

To manually reset the console, press **[*0] RESET** and be ready to continue.

KEY *1

To print the system configuration report, press **[*1] REPORT**.

KEY *2

To put the system in a 'hold' situation and indicate such to the racers, press **[*2] EMERG** to indicate some form of emergency, press **[#]** to return to background monitoring.

KEY *3

This key combination is used to set brightness levels on scoreboards used with the 2700 system. When data is displaying on the scoreboard, press **[*3]** to enter Brightness mode, then press keys 1 thru 8 to set the desired brightness level (1 is brightest, 8 dimmest) is displayed. Press **[#]** to return to background monitoring. Scoreboards must be firmware level H.x or later. The scoreboards will retain this setting as long as they are powered ON.

KEY *4

Press the **[*4] SYSTEM** key on the Keypad to enter the system configuration menu to set test, print, speed trap and custom header parameters. See Fig 10 for the full menu.

KEY *5

To review system diagnostics (Sensor Alignment, Battery Levels and RF Signal Integrity), press **[*5]** to enter the DIAGNOSTIC mode. Repeated presses of the **[5]** key will cycle between the different sections; press **[#] ENTER** to monitor the displayed status; press **[#] ENTER** again to return to system operation. See the section on **ALIGNMENT MODE** earlier in this manual. See Fig 9 for the full menu.

KEY *6

Press the **[*6] TIME** key on the Keypad to set the time of day for display on scoreboards used with the 2700. The time is maintained until new data is received or the scoreboard is powered on. Scoreboards must be firmware level H.x or later.

KEY *7

To manually print the timeslip to the printer, press the **[*7] PRINT** key. This can be done at any time to verify cabling and printer settings; race results in a test condition may all be zeros. Non-RaceAmerica printers connected to the XL Wireless system must be configured for RS232 serial communications, 9600 baud, No Parity, 1 Stop Bit, No Handshake; these parameters can be set on the printer (a custom cable may be required).

KEY *8

Press the **[*8] CONFIG** key on the Keypad to enter the system configuration section menu to set Tree, Data Display and race finish point. See Fig 11 for the full menu.

KEY *9

Press the **[*9] COUNT** key on the Keypad to set a countdown timer up to 60 minutes on scoreboards used with the 2700. The countdown continues until it reaches zero, new data is received and power is ON. Scoreboards must be firmware level H.x or later.

KEY **2

Press **[**2]** to send test data to scoreboards.

STATUS DISPLAY MESSAGES

During normal operation, messages will appear in the Console Display. These messages indicate status, mode of operation, or events occurring on the race track. Many of these messages are covered elsewhere in this manual and are alphabetically summarized in the following section as a reference:

ALiGn

This message indicates the system is entering the alignment mode for checking the alignment of the emitter/sensor pairs on the track.

AutoPr

Displays in the upper display during configuration for the number of timeslips to auto print after each race.

DiALin

Displays in upper display when selecting the starting Tree format if a Dial-in other than zero is entered.

End

This messages indicates all starting vehicles for that pair of lanes have crossed the finish line and the run is over.

Full

Full (Sportsman) starting format Tree is selected.

LF

During configuration of the printer, the user is prompted to enter the desired number of line feeds to be added to each timeslip to properly eject the paper for tear-off from the printer.

OFF

Displays for selection to disable various options.

on

Displays for selection to enable various options.

PC EnAbLE

Displays when PC is in command. Marks PC only functions.

PrE-St

Displays in the upper display during configuration or Pre-Stage functionality.

I---F

Background monitoring is indicating the left finish sensor id out of alignment.

SEnSor tESt

Displays when background sensor monitoring is active and all sensors are properly aligned.

S6SESF

When entering Alignment Mode, this message will appear in sequence to indicate the alignment of the Track Sensors and Beam Emitters will be continuously monitored and the results displayed; left lane in upper display, right lane in lower display (Start, 60ft, Half-Track Speed, Half-Track ET, Full-Track Speed, Full-Track Speed).

Print SLiP

Indicates timeslip data is being sent to the printer ports..

Pro

PRO starting format Tree is selected.

SPEEd

Displays in configuration setup to enable or disable the Speed option. If sensors are not connected to the system, Speed must be OFF.

StAGE

Appears in the Pre-Stage configuration; selection of Stage will turn on the Pre-Stage lights when the Stage lights come on as a vehicle stages.

60 Ft

Displays in configuration setup to enable or disable the 60 Ft option. If sensors are not connected to the system, 60 Ft must be OFF.

TROUBLE SHOOTING

Some operational conditions which may cause operational problems or be symptomatic of problems which should be addressed are listed here with solutions.

Alignment problems - Use new emitter batteries; interchange positions of similar units to isolate specific emitter, sensor or cable problems; disable positions to continue event.

Tree Light turns ON/OFF - Using Alignment Mode, switch sensors to isolate the problem to the tree, cables or sensors.

Intermittent flickering of tree lights - check power supply for momentary over voltage condition.

System resets at power-up or when the Tree comes down - Check power supply for low voltage condition; may manifest itself as a generator surging or bogging down; check for adequate wire gauge on long power runs and extension cords.

Scoreboards do not display correct results. After determining the communications are correctly cabled or wired, press **2 from the keypad to display simulated race results. The scoreboards should show 12.345/135.79 for the left lane ET/Spd and 67.890/246.80 for the right lane ET/Spd.

CONNECTING PERIPHERAL DEVICES

The XL Wireless console can be connected to a variety of peripheral devices including PCs, Printers, Scoreboards and a Starter's Button. The printer is connected via cable or wireless RF data links.

The **Starter's Button** (06-27SB) connects at the starting line on the back of the tree. The Starter's Button functions exactly as the **[0] RUN** console key and in parallel with it.

Other peripherals are connected via Wireless RF Links which work best with line of site

operation and operate to distances in excess of a quarter mile.

RaceAmerica Scoreboards (models 6528, 6828, 6628, 6428, 6810, 6610 and 6410) can be connected with internal or external wireless units. Scoreboard data is sent immediately and automatically at the conclusion of a race as the data is displayed on the console. Scoreboards contain internal 'smarts' to sort the data string and display the race results (selected by DIP switch settings on each display unit). Choices include Left/Right Lane data, ET, Speed, RT, winner indication (flash winning lane) or alternating between Speed and ET (6528, 6828, 6628 and 6428 models only). Additionally, eight brightness levels, time of day display and a countdown timer are available for special situations and managing your event.

A printer is a desirable peripheral to print timeslips for the participants. Printers receive a special output format transmitted serially at 9600 baud.

RACE MANAGEMENT SOFTWARE

RaceAmerica XL Score PRO Race Management Software can be used to control the Model 2700 XL Wireless timing system to manage the racing action. XL Score PRO is PC based software which includes Classes, Driver Registration, Practice, Qualifications, Eliminations Ladder creation (up to 64 cars per class) and status output in HTML format for viewing in networked web browsers. See the XL Score PRO manual (part no. 3128B) for additional details. Some 2700 functions are not available in PC mode.

WIRELESS FIRMWARE UPDATE

The 2700 console internal firmware (A.31 and later) can be updated in the field using a PC Utility program and the wireless network. A wireless link unit on the same optimizer code as the console is required with the PC. If using XL score Pro software, the PC wireless modem will work with the utility software. Follow on-screen instructions with utility to complete the update. Call RaceAmerica for details.

MAINTENANCE

The 2700 Series Console, Beam Emitters, and Track Sensors do not require any maintenance beyond simple cleaning. Keep your system components dry between uses.

To insure uninterrupted operation on raceday, it is suggested to keep track of battery usage hours so as to have fully charged batteries. T-Link units should be kept at more than 40% charged. Plan to replace the alkaline AA cells in the Beam Emitters after about 60 hours use. If you are using rechargeable AA cells, recharge them each day. Low battery voltage (Emitters below 4.5VDC) will cause intermittent operation of the system resulting in intermittent cars detected at the starting line or the finish line as the battery power weakens.

To maintain the highest level of timing accuracy and minimize false trips, annual preventative maintenance and calibration should be performed on all system track sensors and beam emitter units.

SPARE PARTS

To minimize race program interruptions, RaceAmerica recommends the purchase of spare parts. A spare emitter/sensor pair and end of track cable sections should be available in the event of an unfortunate accident during a program. Contact RaceAmerica for availability and pricing of spares items.

SUPPORT AGREEMENTS

Support agreements are available from RaceAmerica providing Telephone Assistance on technical issues and operational questions, repair and/or replacement of hardware failures, Software and Firmware updates and bug reporting, and Annual Preventative Maintenance on all system track sensors and beam emitter units. Contact RaceAmerica for more information and pricing of Support Agreements.

TIMESLIP HEADER

The 2700 Series Console allows custom timeslip header input for four lines of up to 39 characters each to print at the top of each timeslip. Input for the Timeslip Header is found in the **[ConFig] [HEAdEr]** menu. Once the configuration is input, it is saved until changed or deleted. Input is from the keypad via a two-digit code for each character. The console display prompts for each line, character and character code (existing or new) being input.

The following table lists the codes for each character (note: upper and lower case letters have different codes). Use the worksheet on the next page to lay out the desired print text and cross-reference the codes for sequential input. Only desired text including spaces need to be input for each line; any line or lines can be left blank also.

Character	Code	Character	Code	Character	Code
Space	00	A	33	a	65
!	01	B	34	b	66
@	02	C	35	c	67
#	03	D	36	d	68
\$	04	E	37	e	69
%	05	F	38	f	70
&	06	G	39	g	71
'	07	H	40	h	72
(08	I	41	i	73
)	09	J	42	j	74
*	10	K	43	k	75
+	11	L	44	l	76
'	12	M	45	m	77
-	13	N	46	n	78
.	14	O	47	o	79
/	15	P	48	p	80
0	16	Q	49	q	81
1	17	R	50	r	82
2	18	S	51	s	83
3	19	T	52	t	84
4	20	U	53	u	85
5	21	V	54	v	86
6	22	W	55	w	87
7	23	X	56	x	88
8	24	Y	57	y	89
9	25	Z	58	z	90
:	26	[59	{	91
;	27	v	60		92
<	28	l	61	}	93
=	29]	62	~	94
>	30	-	63		
?	31	'	64		
@	32				

Fig 14 - Timeslip Header Character Codes

TIMESLIP LAYOUT WORKSHEET

Character Position	1	2	3	4	5	6	7	8	9	10	11	12	13	14	15	16	17	18	19	20	21	22	23	24	25	26	27	28	29	30	31	32	33	34	35	36	37	38	39				
Printed Character																																											
Character Code																																											
Printed Character																																											
Character Code																																											
Printed Character																																											
Character Code																																											
Printed Character																																											
Character Code																																											

Line 1
Line 2
Line 3
Line 4

Fig 15 - Timeslip Header Character Code Worksheet

7540C - Foam Stand Assembly Instructions

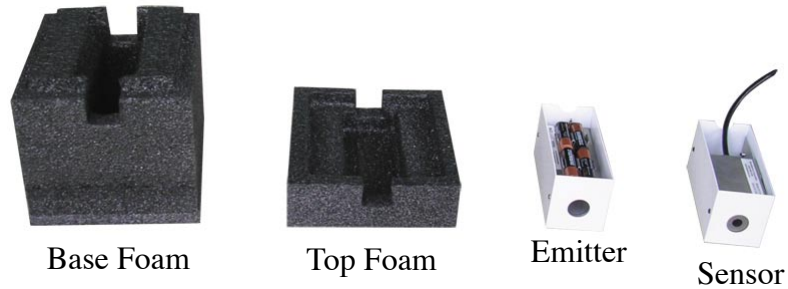

Assembly Components

'AA' Battery Emitter (5040B, 5050B & 5058B)

1. Install batteries and turn on the Emitter.
2. Separate the Base of the Foam Stand from the Top.
3. Place the 5040/5050/5058 Emitter into the Base foam with the battery side down.
4. Slide the Top on the Base. Place on the track.

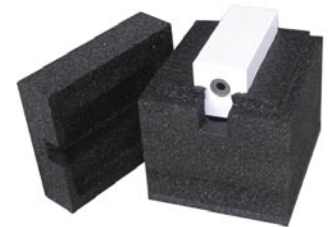

Sensor/Emitter placement in Foam Base

Track Sensor (5140D & 5158D)

1. Separate the Base of the Foam Stand from the Top.
2. Connect the cable to the sensor
3. Place the 5140/5158 Sensor into the base (open end down)
4. Press the Top on the Base. Place on the track.



Sensor back
Note cable routing

'C' Battery Emitter (5042B)

1. Same as above except place the 'C' Battery pack in the Base standing on its edge.

For additional stability

1. Place weight in the Base well as required.

Outside Dimensions:

6.5" W x 7.25" L x 7.5" H



Complete Assembly